

# Modell: DESK 800

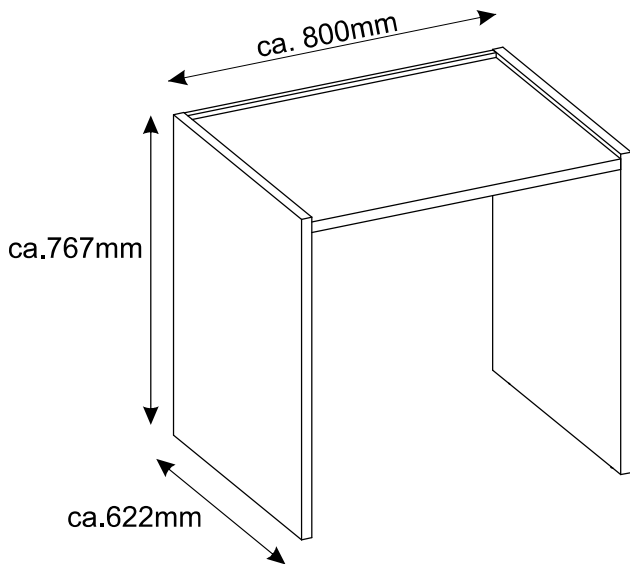

- Ⓓ **Montageanleitung**
- Ⓐ **Handleiding voor de montage**
- Ⓓ **Montaj talimatı**
- Ⓕ **Notice de montage**
- Ⓒ **Montážní návod**
- Ⓗ **Szerelési útmutató**
- Ⓒ **Assembly instructions**
- Ⓐ **Instrukcja montażu**
- Ⓔ **Инструкция по монтажу**
- Ⓘ **Istruzioni di montaggio**
- Ⓐ **Návod na montáž**
- Ⓓ **Instrucțiunile de montaj**
- Ⓔ **Instrucciones de montaje**
- Ⓓ **Montaj Talimatı**

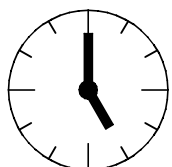
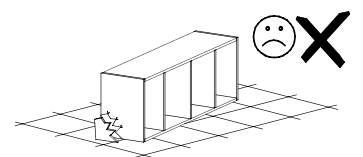
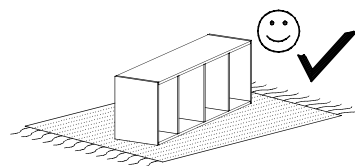
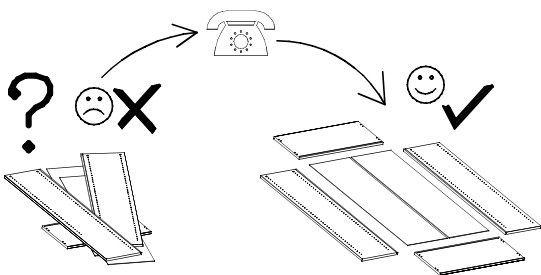
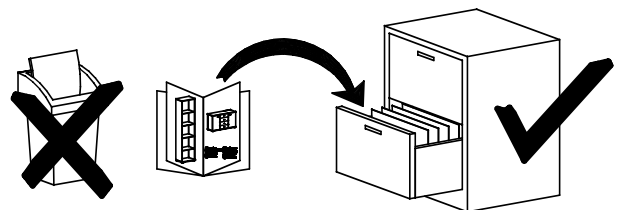
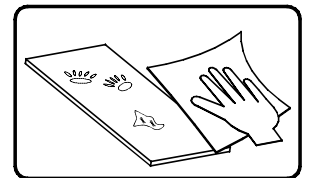
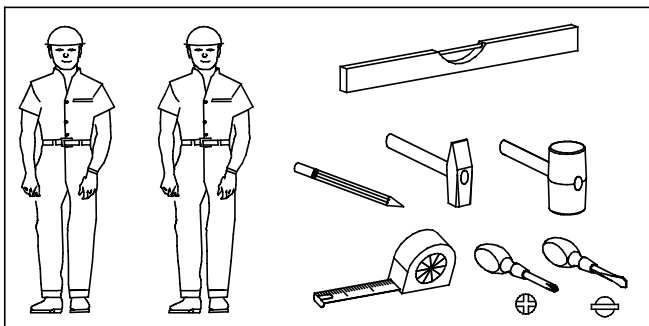

0,5h

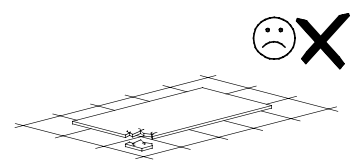
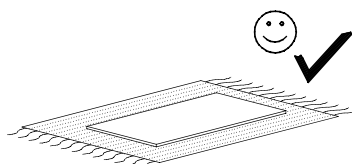

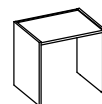

nr	L[mm]	B[mm]	T[mm]	Menge	Colli
1	762	622	25	1	1/1
2	762	622	25	1	1/1
3	750	604	25	1	1/1
4	750	280	16	1	1/1

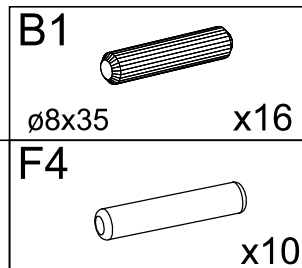
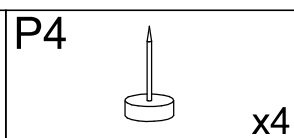
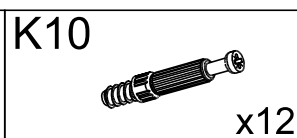
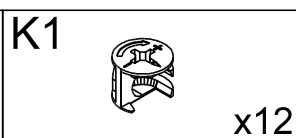
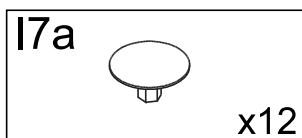
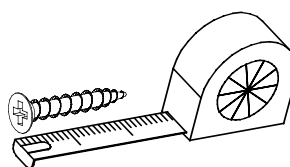
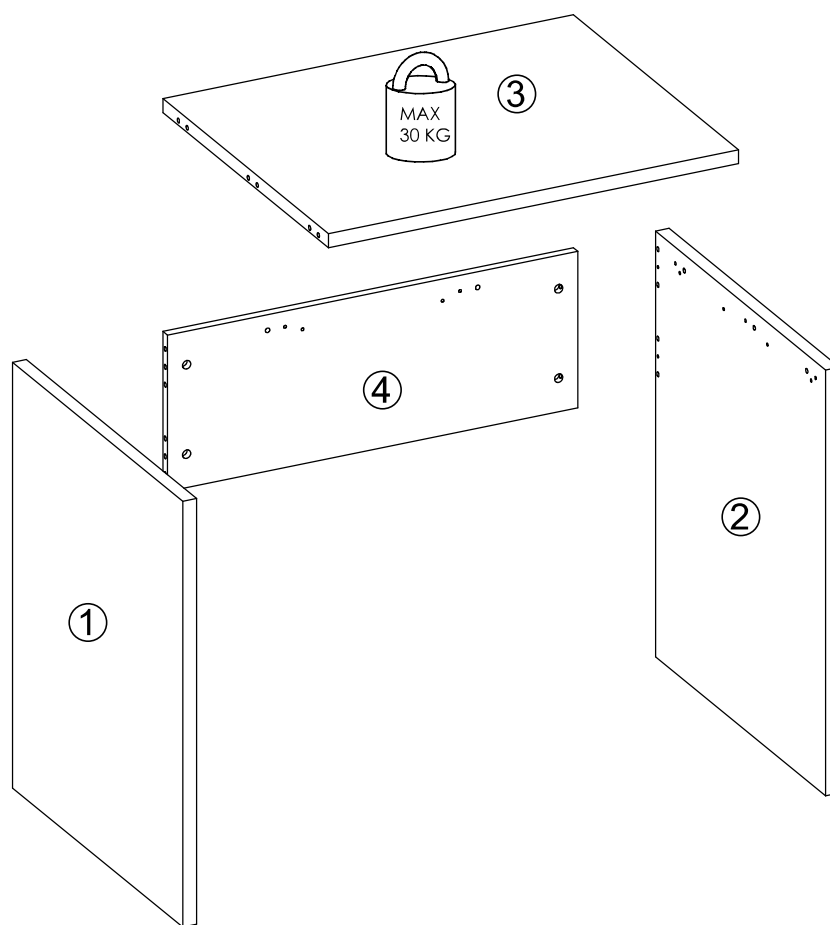

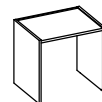

I

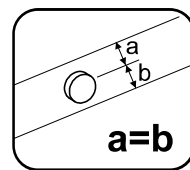
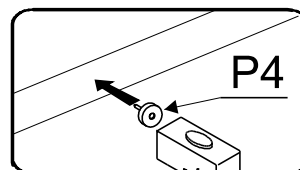
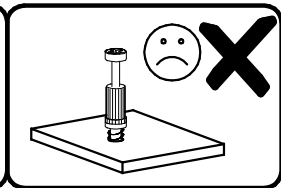
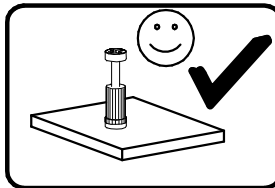
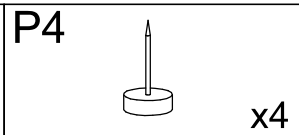
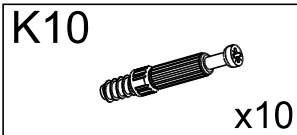
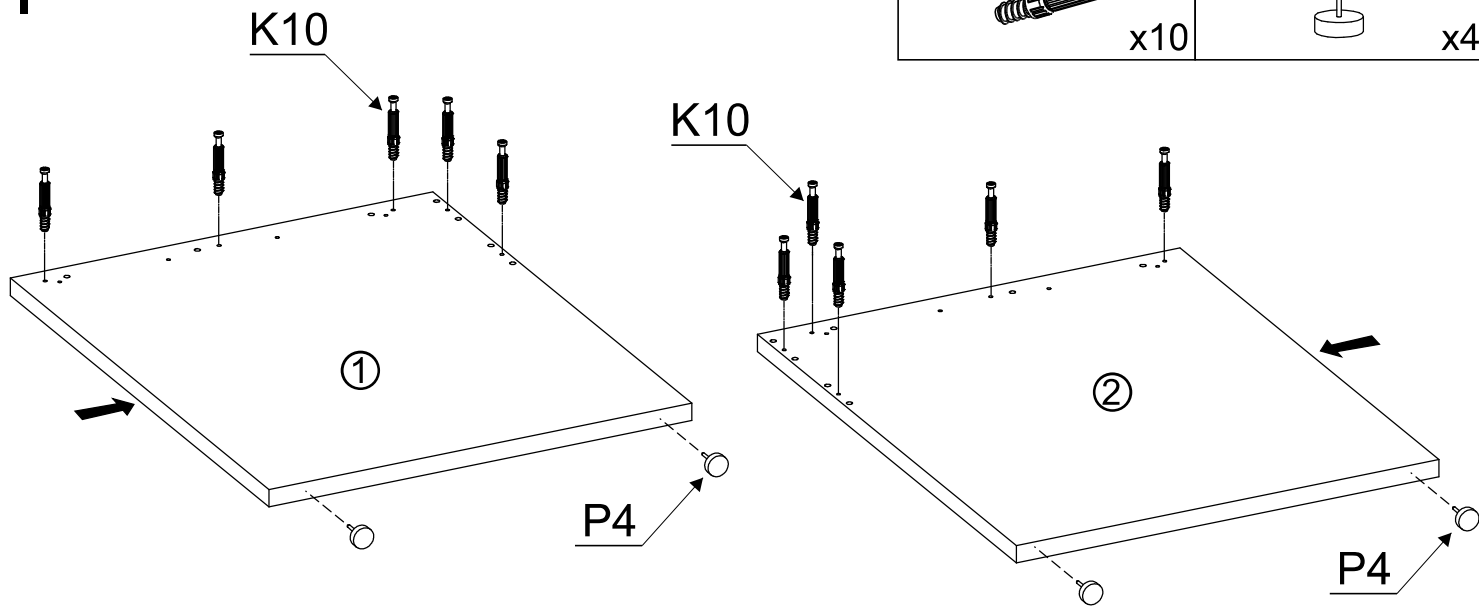

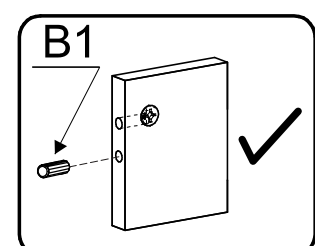
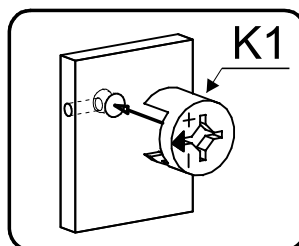
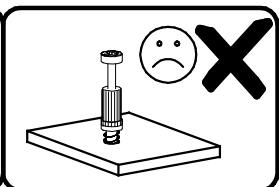
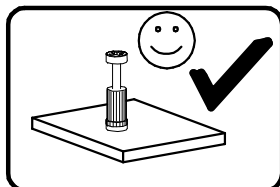
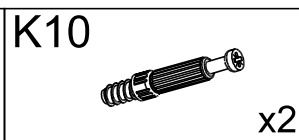
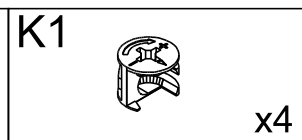
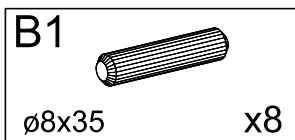
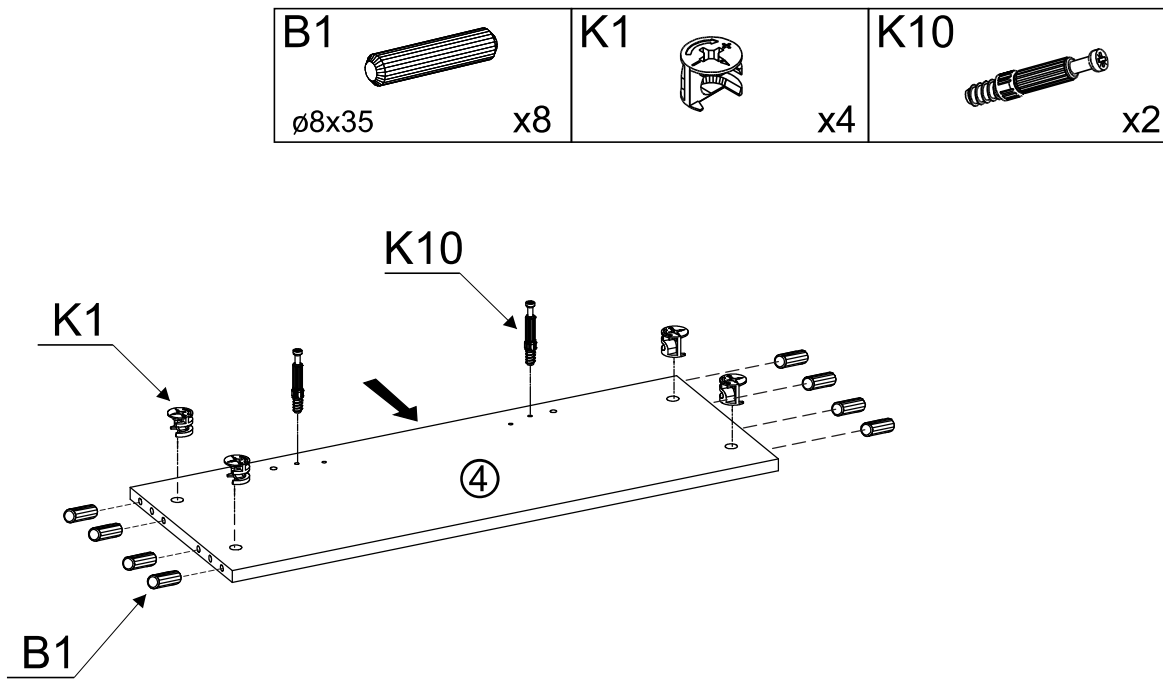

II

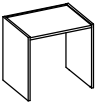



III

B1  ø8x35 x8	K1  x8
---	---

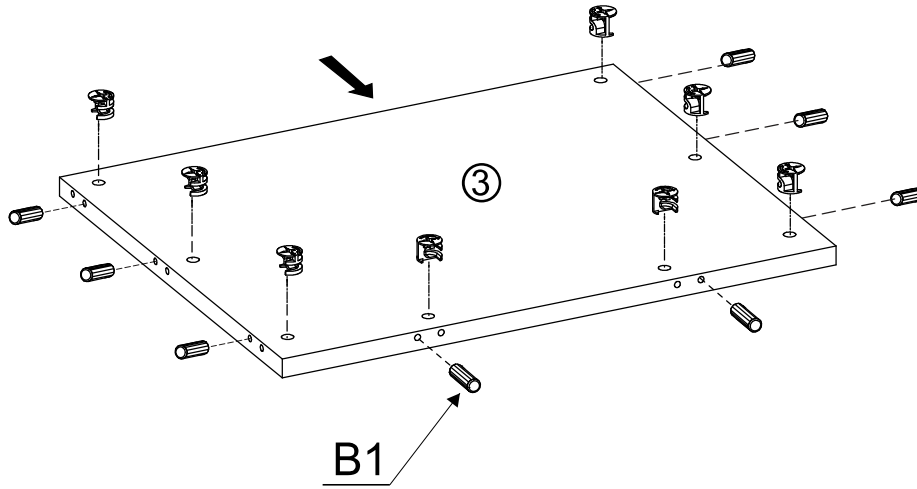

IV

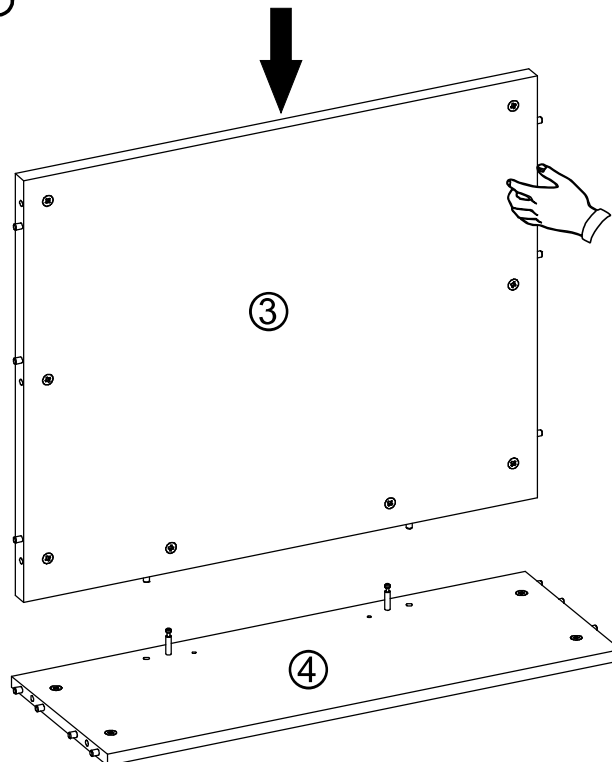
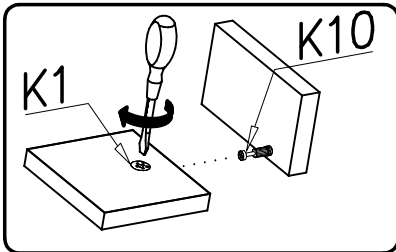

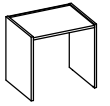

V

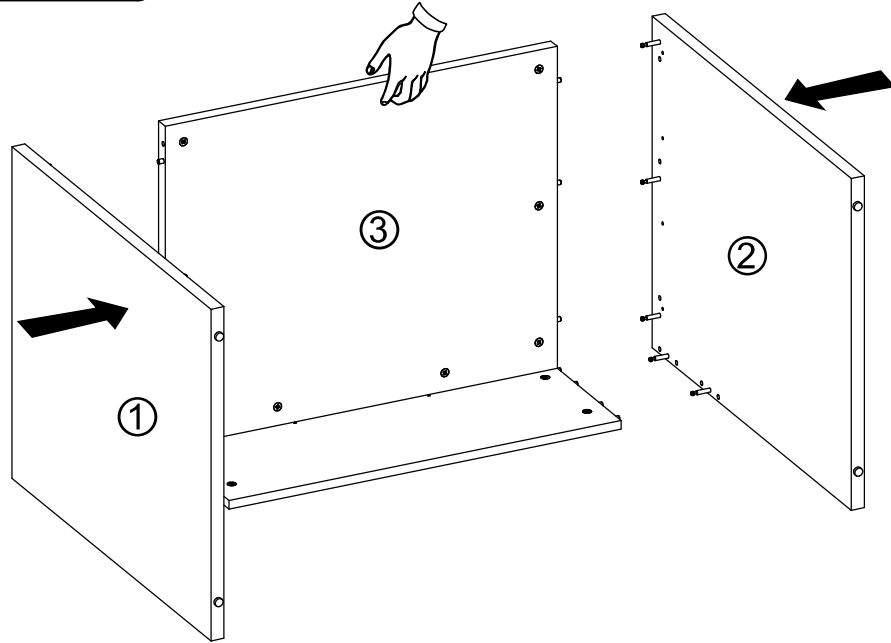
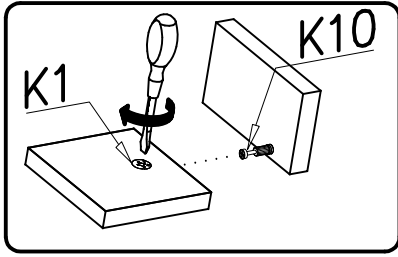

VI

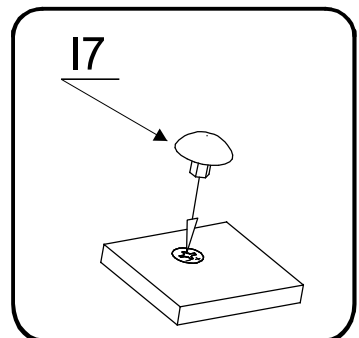
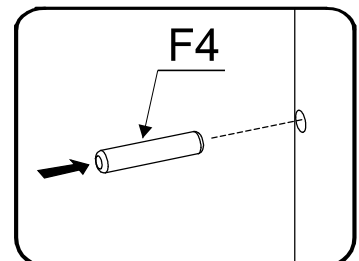
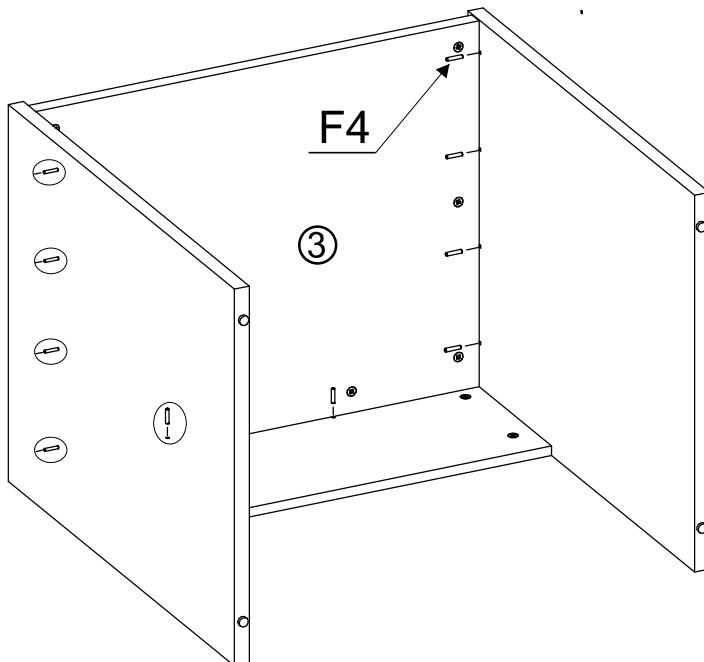
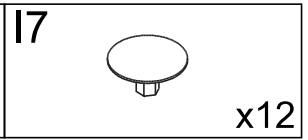
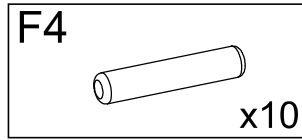

Name • Nom • Nome • Naam • Nazwa • Имяно  
• Názov • Név • Denumire • Isim • Извание

Nr • No • N° • Номер • Č • Sz

Typ • Type • Tip • Típus • Tipo • Tun

DESK 800

— —

...

Unser Direktservice für Beschlagteile

Sollte Ihnen ein Beschlagteil fehlen, können Sie diese Servicekarte direkt an die untenstehende Adresse mailen. Wir können allerdings nur Beschlagteile auf diesem Wege verschicken. Sollten Sie eine andere Beanstandung an Ihrem Möbelstück haben, so wenden sie sich bitte direkt an Ihr Möbelhaus.

Our direct order service for fitting

If a fitting part is missing, you can e-mail this service card directly to the address below. However, we can only send fitting parts in this way. If you have any other cause for complaint concerning your item of furniture, please contact your furniture store directly.

Naše primé služby pro kování

Chybí-li vám nějaký díl z kování, můžete tuto servisní kartu odeslat e-mailem přímo na níže uvedenou adresu. Tuto cestou však můžeme rozeslat jen díly kování. Pokud byste reklamovali jiný díl nábytku, obraťte se přímo na svého prodejce nábytku.

Bien etudier la notice de montage

S'il vous manque une ferrure, veuillez envoyer directement la présente carte service à l'adresse e-mail indiquée ci-dessous. Cependant, ceci nous permet uniquement d'envoyer des ferrures. Pour tout autre type de réclamation concernant votre meuble, veuillez contacter directement votre magasin d'ameublement.

Il nostro servizio diretto per l'ordine della ferramenta

Qualora Vi dovesse mancare un pezzo di fissaggio, allora Vi preghiamo di inviare questa carta di servizio immediatamente all'indirizzo sottostante. Possiamo inviare i pezzi di fissaggio solamente per mezzo di questo procedimento. Qualora dovete avere qualche altra reclamazione in merito al mobile, allora Vi preghiamo di rivolgerVi direttamente al Vostro Negoziò di mobili.

İaşa òa aèòàèòà òñèòàà çà İaèİa

Aèİ èèİñààò +àñòè İò èèİèèè òà, İñüèİa òà İañoñÿüà òà İàòàèçİa èàòòà è İè ÿ èçİòà òàòà İà e-mail aàòàñà, İİñİ-àİ İİ-àİ èò, İİ òİ çè İa-èİ İİaèàİ àà àİñò aàÿİa İaİİ èèİñà àùè àèaİaİòè İ ò İaèİaà. Aèİ òñòaİİaèò a aòòàè ààòàèòè İİ İaà èèèò. Aè İñààòààİa àà İà İà İà òà İaòİaòà èüİ İà ààèİaòà èüüà/İaà açèİ, İ ò èİèòİ òòà çàèèòİèèè òòèèàòà.

Onze directservice voor losse onderdelen

Wanneer er een onderdeel ontbreekt, kunt u deze servicekaart direct aan onderstaand e-mailadres sturen. Wij kunnen langs deze weg echter alleen beslagdelen versturen. Mocht u een ander probleem aan uw meubel hebben, verzoeken wij u contact op te nemen met uw meubeldealer.

Nasz bezposredni serwis czesci montazowych

Jeżeli brakuje czesci koniecznych do montazu, prosimy o przeslanie nam niniejszej karty serwisowej na nizej podany adres e-mailowy. W ten sposob mozemy przeslac Państwu tylko brakujace czesci. W przypadku innych reklamacji dotyczacych mebla, prosimy zglosic sie do salonu meblowego, w którym zostal dokonany zakup.

Servis za okove

U sluèaju da nedostaje neki od dijelova molimo vas da na dolje navedenu mail adresu pošaljete ovaj servisni obrazac. Na ovaj naèin mogu se dostaviti samo okovi. U sluèaju da imate dodatne prigovore vezane uz komad namještaja molimo vas da se obratite izravno trgovini namještaja gdje je isti kupljen.

Direktszolgálatunk vasalatok esetén

Ha hiányzik egy vasalat, ezt a kártyát közvetlenül elküldheti az alább található címre. Azonban csakis vasalatokat tudunk így küldeni. Amennyiben másfajta reklamáció áll fenn bútorárábját illetően, forduljon közvetlenül a bútornázhoz.

Náš priamy servis pre èásti kovania

Ak by Vám chýbala nejaká èasť kovania, môžete poslať túto servisnú kartu poslať e-mailom na nižšie uvedenú adresu. Diely kovania vieme poslať iba týmto spôsobom. Ak by ste mali inú reklamáciu ohľadom Vášho nábytku, obráťte sa priamo na vašu predajcu nábytku.

Naše direktne uslužne storitve za okovje

Èe vam manjka kakšno okovje, lahko to servisno kartico pošljete po e-pošti direktno na spodnji naslov. Po tej poti vam lahko pošljemo samo okovje. Èe želite reklamirati kakšen drug del pohištva, se obrnite neposredno na vašo trgovino pohištva.

Service-ul nostru direct pentru feronerie

În cazul în care vă lipseşte o piesă de feronerie puteţi să trimiteţi direct acest card de service prin e-mail la adresa de mai jos. Noi nu putem expedia piese de feronerie decât pe această cale. Dacă aveţi o altă reclamaţie referitoare la piesa de mobilier, atunci vă rugăm să vă adresaţi direct la magazinul dvs. de mobilă.

İaşò İòÿİİè İàòàèñİ àèÿ İİñò ààİè òòòİèòòò

Añèè İèaààòñÿ, +òİ Aaİ İà òàà òààò òİaİ èèè İİİa İ ÿèaİaòà òòòİèòòò. Aù İİaè òà İòòààèòò òàòàèñİòò èàòòò İ òàè İò İaİİñòà àñòààİİİ İa İèaàİòèà àaàİİüè aàòàñ ÿ èàèòòİİİè İ +òù. İ aİaèİ, òàèèİ İaòàç İİ İù İİaèİ İaòàñüèà òù èèòù òòòİèòòò. Añèè aèa ò Aañ açİèèİòò èİüà İòà òàçİèè İòİİñèòàèüİİ İòèİaòà òaİİİè İa aàèè, İİaèaèòèñòà, İaòàüaèòàñü İaİİñòà àñòààİİİ à İòà àİèçàòèò, İñòüañòàèàòòòò İòİ àààèò.

Vår direktservice för beslagsdelar

Om du saknar en beslagsdel kan du skicka detta servicekort direkt till e-postadressen som anges nedan. Tänk på att detta är den enda möjligheten att skicka beslagsdelar till dig. Om du vill reklamera din möbel av en annan anledning måste du kontakta ditt möbelhus direkt.

Nuestro servicio directo para accesorios

Si le falta algún accesorio, puede enviar esta tarjeta de servicio directamente a la siguiente dirección. No obstante, por este método solo podemos enviar accesorios. Si tiene alguna otra objeción sobre su mueble, consulte directamente con su mueblería.

Donatilar için doğrudan servisimiz

Bir donatınız eksikse bu servis kartını doğrudan a'agıda bulunan adrese doğrudan mail yazabilirsiniz. Sadece bu yolla donatıları gönderebilirsiniz. Mobilyanızda ba'ka \*kayetleriniz varsa lütfen doğrudan mobilya satıcınıza danışın.

nr	L[mm]	B[mm]	T[mm]	Menge	Collt
1	762	622	25	1	1/1
2	762	622	25	1	1/1
3	750	604	25	1	1/1
4	750	280	16	1	1/1

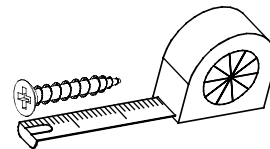
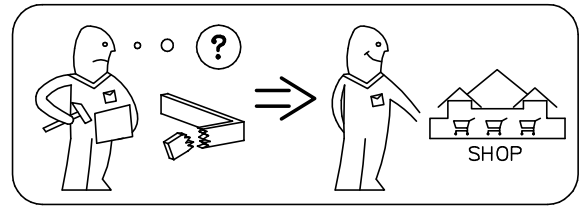
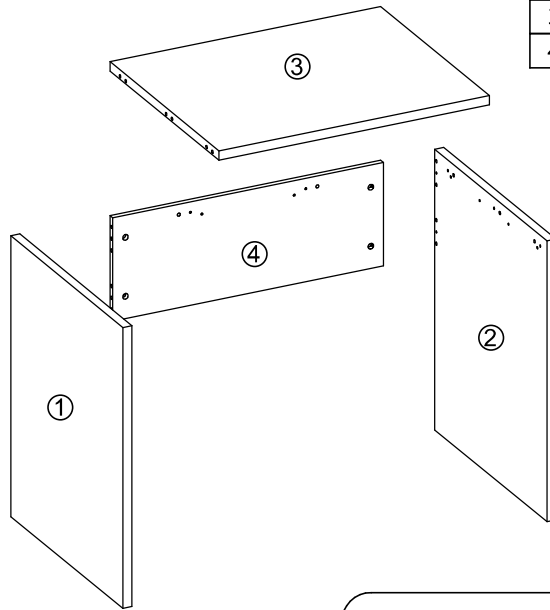

B1 ø8x35 X...	I7 X...	K1 X...
K10 X...	P4 X...	F4 X...

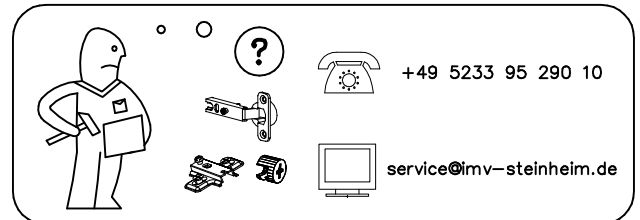
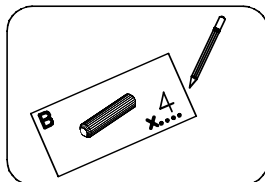

D

GB

CZ

F

I

BG

NL

PL

HR

HU

SK

SLO

RO

RUS

S

ES

TR

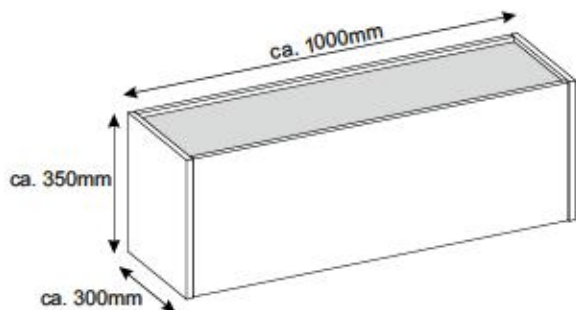

- Ⓛ Montageanleitung
- Ⓝ Handleiding voor de montage
- Ⓜ Montaj talimat
- Ⓧ Notice de montage
- Ⓒ Montážní návod
- ⓗ Szerelési útmutató
- ⓖ Assembly Instructions
- Ⓟ Instrukcja montażu
- Ⓡ Инструкции по монтажу
- Ⓣ Istruzioni di montaggio
- Ⓢ Návod na montáž
- Ⓡ Instrucțiuni de montaj
- ⓔ Instrucciones de montaje
- Ⓡ Montaj Talimat

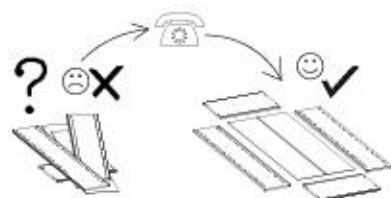
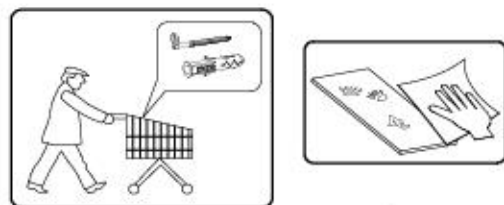
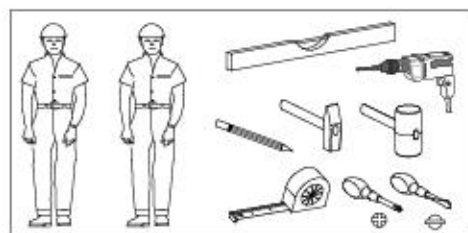

10.03.2023

nr	L[mm]	B[mm]	T[mm]	Menge	Dati
1	350	300	16	1	1/1
2	350	300	16	1	1/1
3	968	266	16	1	1/1
4	968	283	16	1	1/1
5	968	332	16	1	1/1
6	962	347	16	1	1/1

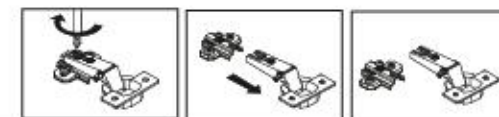
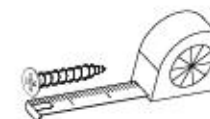
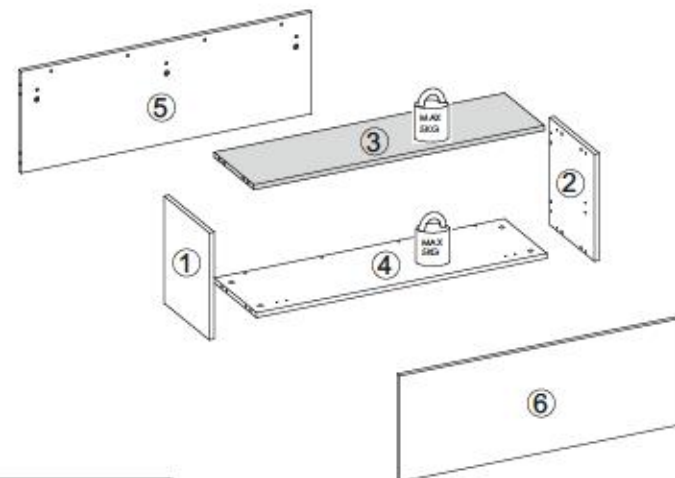

B1 ø8x35 x12	A1 ø7x50 x4	W2 x1	I7a x4	I7b x4
K1 x16	K10 x16	D4 x2	C1 x2	G34 3,5x16 x16
G52 5x11 x6	P10 x3	C10 x2	I8 x3	Q2 x3

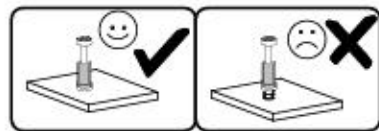
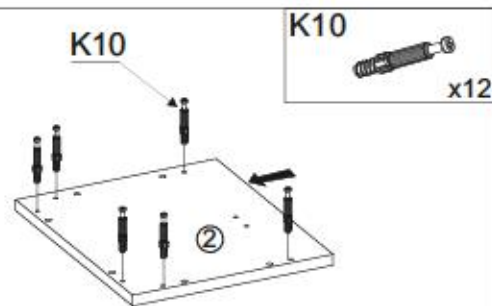
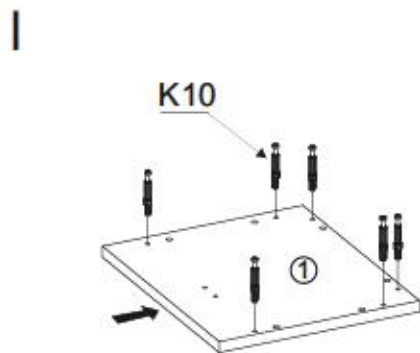

II

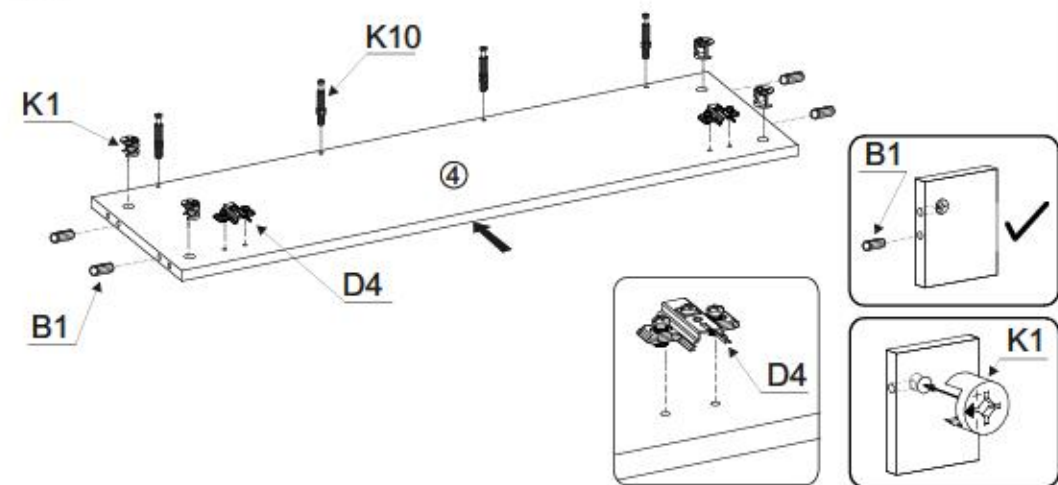
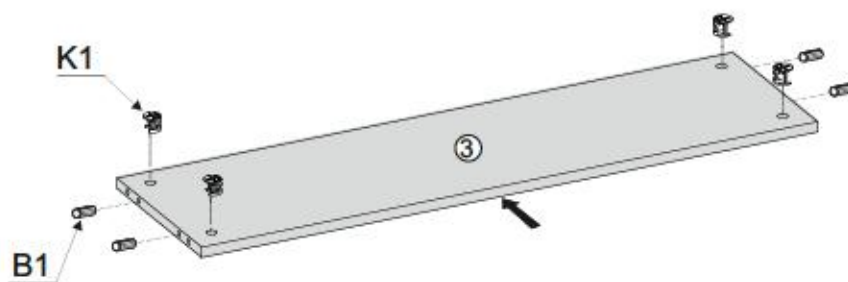

III

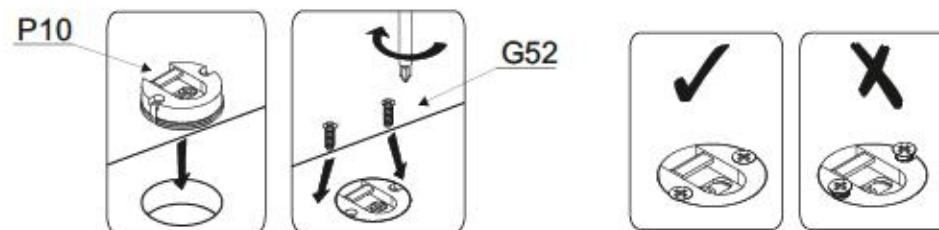
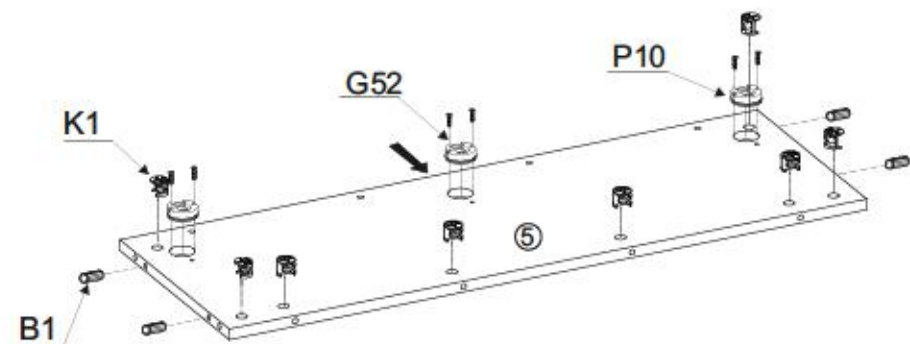
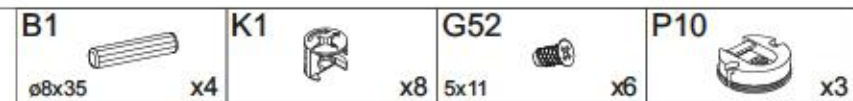

IV

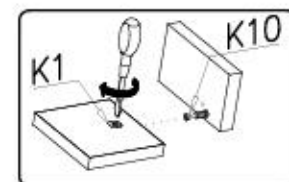
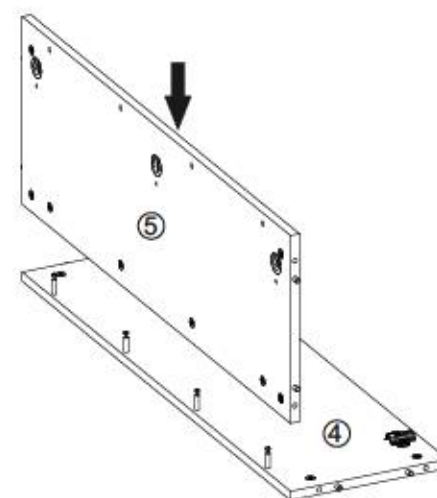



5/11

CITY / GIRON 47



V

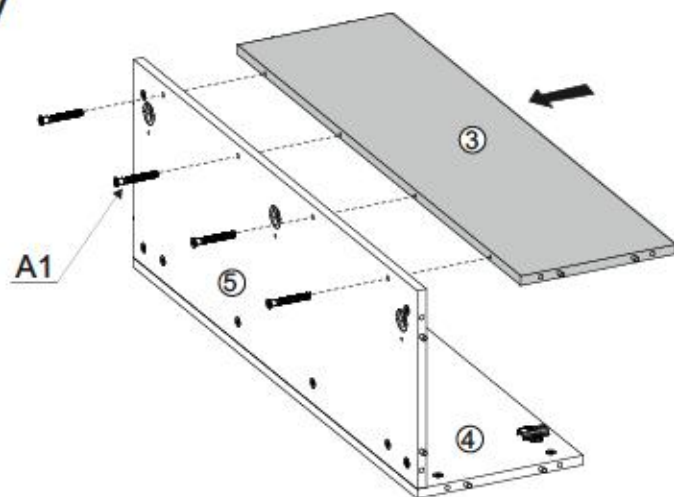

A1



ø7x50 x4

W2



x1

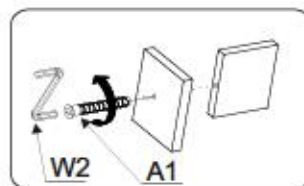

VI

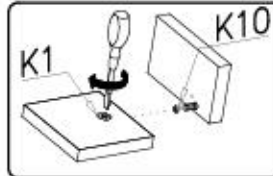
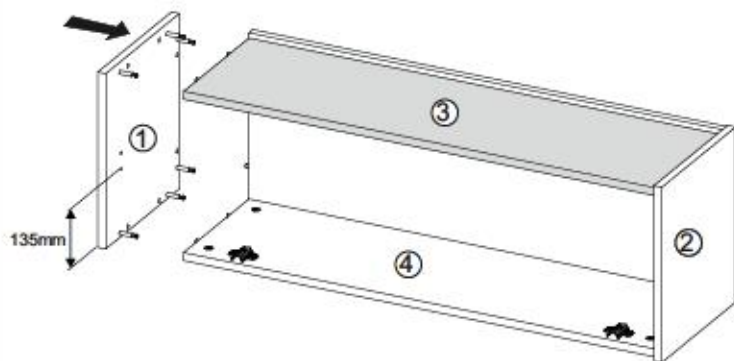
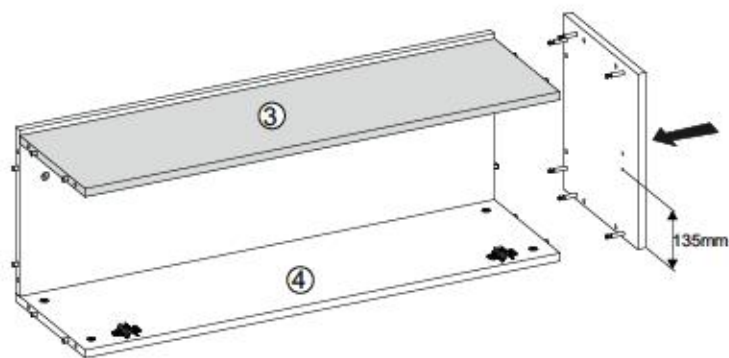

6/11

CITY / GIRON 47



VII

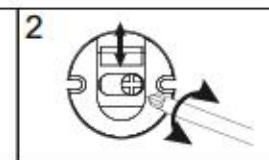
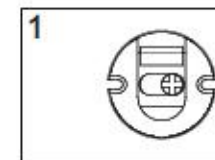
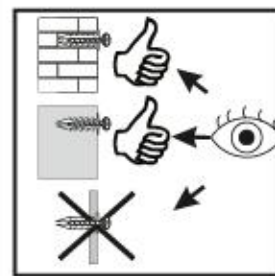
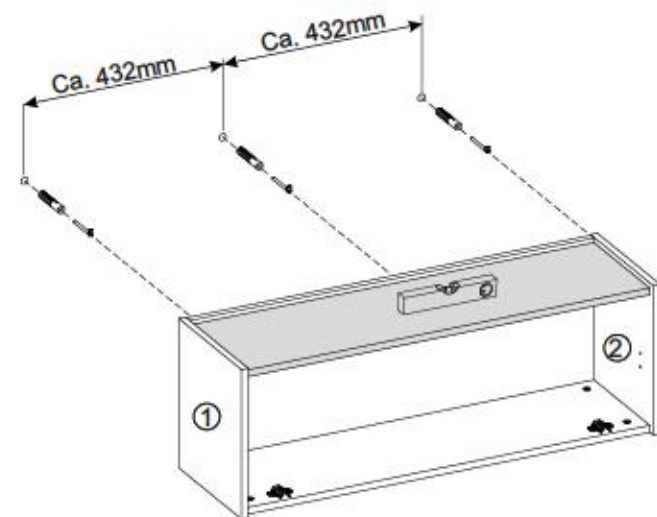
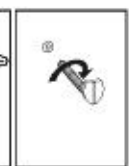
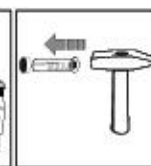
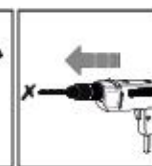
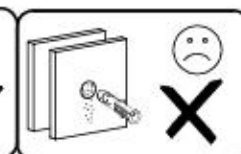
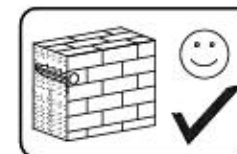

7/11

CITY / GIRON 47



VIII

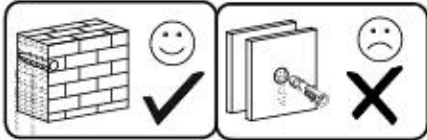
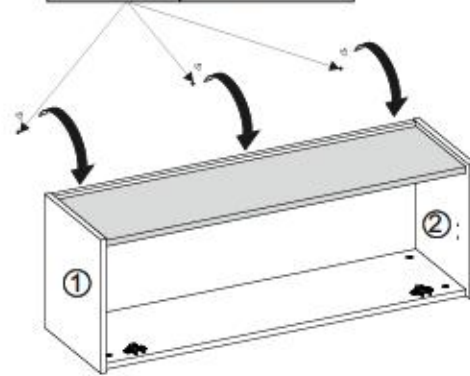
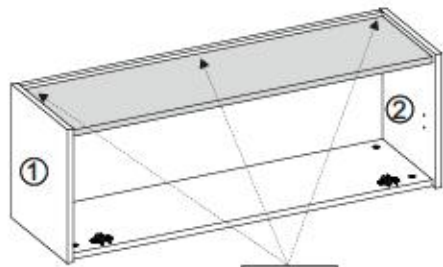

IX

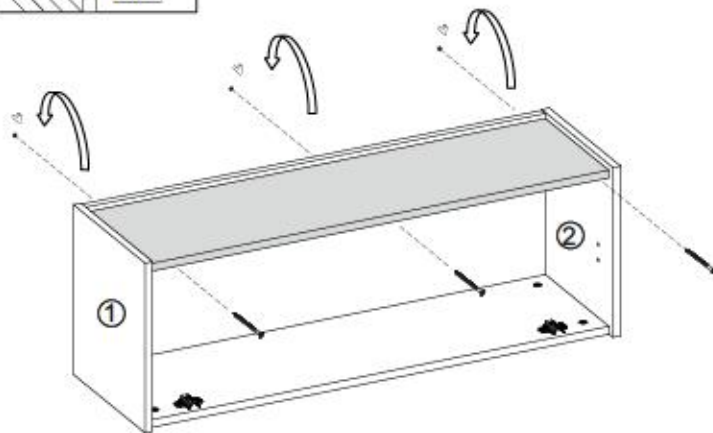
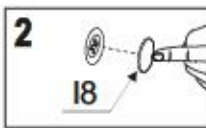
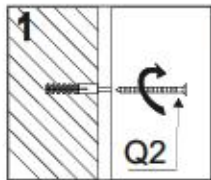

8/11

CITY / GIRON 47



X

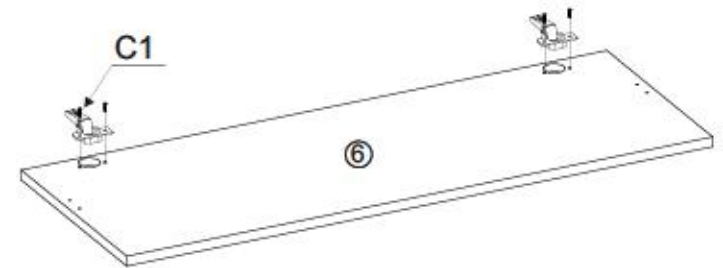
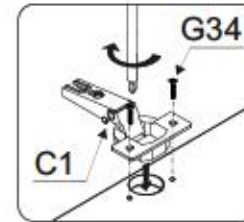

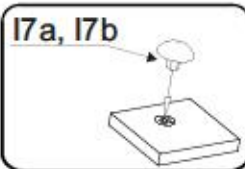
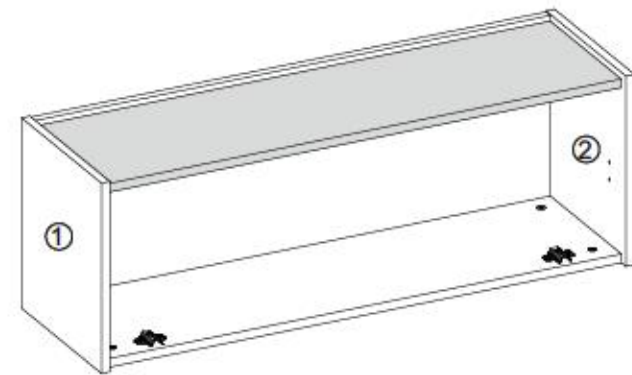
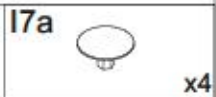

XI



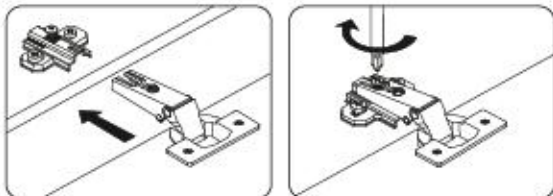

XII



- C10  x2
- G34  x12
- 3,5x16

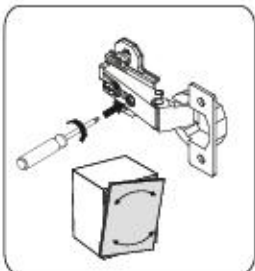
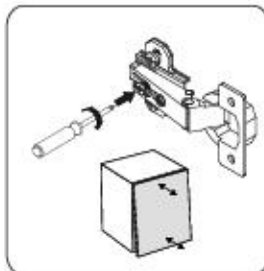
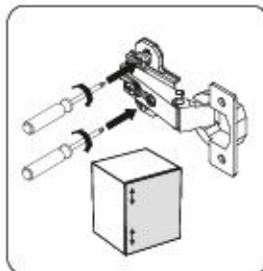
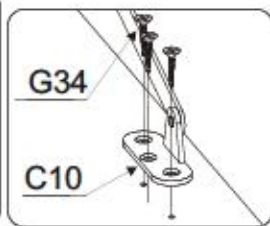
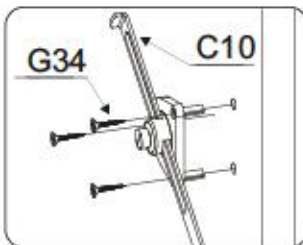
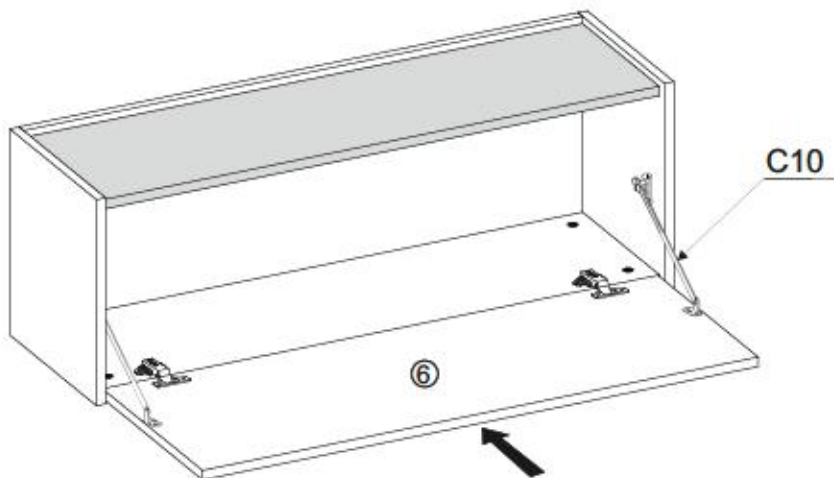

Name • Nom • Nome • Naam • Nazwa • Jméno • Νόζον • Νέυ • Denumire • Isim • Название	Nr • No • N° • Номер • Č • Sz	Typ • Type • Tip • Típus • Тíро • Tun
CITY / GIRON	--	47

**D** **Ukazanie Dostavky a Servisu**  
 Sledujte prosím adresy uvedené níže. Pokud byste měli jakýkoliv dotaz, obraťte se přímo na svého prodejce nábytku.

**GB** Our direct order service for filling  
 If a filling part is missing, you can e-mail this service card directly to the address below. However, we can only send filling parts in this way. If you have any other issues for completion, contacting your item of furniture, please contact your furniture store directly.

**CZ** **Náše příloha slouží pro kování!**  
 Chybí-li vám nějaký díl z kování, můžete tuto servisní kartu odeslat e-mailem přímo na níže uvedenou adresu. Touto cestou však můžeme to poslat jen díly kování. Pokud byste měli nějakou jinou problém, obraťte se přímo na svého prodejce nábytku.

**F** **Bien étudier la notice de montage**  
 Si vous remarque une erreur, veuillez envoyer directement la présente carte service à l'adresse e-mail indiquée ci-dessous. Cependant, ceci nous permet uniquement d'envoyer des pièces détachées. Pour tout autre type de réclamation concernant votre meuble, veuillez contacter directement votre magasin d'ameublement.

**I** **Il nostro servizio diretto per i ordini delle braccette**  
 Qualora Vi dovesse mancare un pezzo di braccette, allora Vi preghiamo di inviare questa carta di servizio immediatamente all'indirizzo sottostante. Possiamo inviare i pezzi di braccette solamente per mezzo di questo procedimento. Qualora dovesse avere qualche altra necessità in merito al mobile, allora Vi preghiamo di rivolgerVi direttamente al Vostro Negozio di mobili.

**BG** **Нашата директна услуга за обби**  
 Ако липсва част от комплект, попълнете настоящата справка и я прагнете на e-mail адреса, посочен по-долу. Тя може да послужи за доставяне само на липсващи елементи от обби. Ако у вас има други дефекти по мебелта, би съветваме да се обърнете към мебелната къмпанията, от която сте закупили стоката.

**NL** **Onze directie voor losse onderdelen**  
 Wanneer er een onderdeel ontbreekt, kunt u deze aanvragen: dit doet u aan onderaand e-mailadres. Wij kunnen langa dees weg echter alleen bestelbare vastzetten. Mocht u een ander probleem met een meubel hebben, verzaken wij u contact op te nemen met uw meubelwiler.

**PL** **Nasz bezpośredni serwis części montażowych**  
 Jeżeli brakuje części montażowych do montażu, prosimy o przesłanie nam niniejszej karty serwisowej na niżej podany adres e-mailowy. W ten sposób możemy przesłać: Pełniaczu tylko brakujące części. W przypadku innych składowej dotyczących mebla, prosimy zgłosić się do salonu meblowego, w którym został dokonany zakup.

**HR** **Servis za okovne**  
 U slučaju da nedostaje neki od dijelova molimo vas da se dođe u veštavanje mail adresom polježe na ovaj servisni obrazac. Na ovaj način mogu se dostaviti samo okovi. U slučaju da imate dodatne prigovore vezane uz lošad namještaja molimo vas da se obratite bravno trgovini namještaja gdje je isti kupljen.

**HU** **Direktrendelgetarunk varabélok esetén**  
 Ha hiányzik egy varabélok, azt a környékét közzéadva elküldhet az alábbi táblázat címre. Azonban csak azokat lehet kiküldeni így kiküldeni. Amennyiben másféle reklamációt kíván közzéadni a termék, forduljon közvetlenül a boltjának.

**SK** **Náš priamy servis pre častí kování**  
 Ak by Vám chýbala nejaká časť kování, môžete poslať túto servisnú kartu poslať e-mailom na nižšie uvedené adresu. Cieľou kování vieme poslať iba týmto spôsobom. Ak by ste mali inú reklamáciu ohľadom vášho nábytku, obráťte sa priamo na vášho predajcu nábytku.

**SLO** **Náša direktna usluga za obbi za okovje**  
 Če vam manjka kakšno delico, lahko to naročimo lastično polježe po e-pošti direktno na spodnji naslov. Po tej poti vam lahko pošljemo samo okovje. Če imate kakršnakoli kakšen drug del pohištva, se obrnite neposredno na vašo trgovino pohištva.

**RO** **Serviciu la nostru direct pentru braccette**  
 În cazul în care vă lipseşte o piesă de braccete, puteţi să trimiteţi direct acest card de serviu prin e-mail la adresa de mai jos. Noi nu putem expedia piesa de braccete decât pe această cale. Dacă aveţi o altă reclamaţie referitoare la piesa de mobilă, atunci vă rugăm să vă adresaţi direct la magazinul dvs. de mobilă.









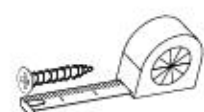





**RUS** **Наш прямой сервис для поставки фурнитуры**  
 Если обнаружено, что Вам не хватает той или иной комплектной фурнитуры, Вы можете отправить сервисную карту по адресу непосредственно на указанный ниже адрес электронной почты. Однако, таким образом мы можем переослать лишь фурнитуру. Если же у Вас обнаружены иные проблемы относительно прочей мебели, пожалуйста, обращайтесь непосредственно в организацию, осуществляющую продажу.

**S** **Vår direkte tjena för beställningar**  
 Om du saknar en beställbar del till ditt skåp, kan vi skicka den till dig direkt. Vi kan endast skicka sådana delar på detta sätt. Om du har andra frågor om ditt skåp, vänligen kontakta den butik där du köpte ditt skåp.

**ES** **Nuestro servicio directo para accesorios**  
 Si le falta algún accesorio, puede enviar esta tarjeta de servicio directamente a la siguiente dirección. No obstante, por este método solo podemos enviar accesorios. Si tiene alguna otra objeción sobre su mueble, consulte directamente con su mueblería.

**TR** **Donanlar için doğrudan teslimatlar**  
 Bir donanım eksikliği ya da servisi için doğrudan talep etmek isterseniz, lütfen aşağıdaki adresi kullanarak doğrudan mail ile talebinizi bildirin. Ancak bu yöntemle sadece donanım parçalarını gönderebiliriz. Mobilyanızda başka bir sorunu ya da başka bir sorunu bildirmek için doğrudan mağazaya başvurmanız gerekir.



B1  x...	A1  x...	W2  x...
I7a  x...	I7b  x...	K1  x...
K10  x...	D4  x...	C1  x...
G34  x...	G52  x...	P10  x...
C12  x...	I8  x...	Q2  x...



+49 5233 95 290 10

service@mv-steinheim.de

Name • Nom • Nome • Naom • Nazwa • Jméno • Názov • Név • Denimire • İsim • Имя  
 CITY / GIRON  
 Nr • No • N° • Номер • Č • Sz  
 Typ • Type • Tip • Típus • Tipo • Тип  
 --- 47

**D** Unsere Dienstleistung ist für Beschädigte  
 Sollte Ihnen ein Beschädigter fallen, können Sie diese Servicekarte direkt an die untenstehende Adresse mailen. Wir können als Ersatz nur Beschädigte auf diesem Wege verschicken. Sollten Sie eine andere Bauschwendung an Ihrem Möbelstück haben, so wenden Sie sich bitte direkt an Ihr Möbelhaus.

**GB** Our direct order card is for filling  
 If a filling part is missing, you can e-mail this service card directly to the address below. However, we can only send filling parts in this way if you have any other claims for complaint concerning your item of furniture, please contact your furniture store directly.

**CZ** Náš přímý službu pro kování  
 Chytl-li Vám nějaký díl z kování, můžete tuto službu kartu odeslat e-mailem přímo na níže uvedenou adresu. Touto cestou však můžeme poslat jen díly kování. Pokud byste měli nějakou jinou díl robit, obraťte se přímo na svého prodejce nábytku.

**F** En attendant la notice de montage  
 Si vous manque une ferrure, veuillez envoyer directement la présente carte service à l'adresse e-mail indiquée ci-dessous. Cependant, ceci nous permet uniquement d'envoyer des ferrures. Pour tout autre type de réclamation concernant votre meuble, veuillez contacter directement votre magasin d'ameublement.

**I** Il nostro servizio di aiuto per il ordine dei ferromenti  
 Qualora Vi dovesse mancare un pezzo di fissaggio, allora Vi preghiamo di inviarci questa carta di servizio immediatamente affinché il pezzo arrivi subito. Possiamo inviare i pezzi di fissaggio solamente per mezzo di questo procedimento. Qualora dovete avere qualche altra reclamazione in merito al mobile, allora Vi preghiamo di rivolgerVi direttamente al Vostro Negozio di mobili.

**BG** Нашата директна услуга за обичай  
 Ако липсват части от комплект, потържете местоположението на доставчика на мебелта и направете на e-mail адреса, посочен по-долу. По този начин можем да доставим само липсващи елементи от обичай. Ако установите други дефекти по мебелта, Ви съветваме да се обърнете към мебелната компания/магазин, от който сте закупили обичай.

**NL** Onze directservice voor losse onderdelen  
 Wanneer er een onderdeel ontbreekt, kunt u deze servicekaart direct aan onderstaand e-mailadres sturen. Wij kunnen langzame deze weg echter alleen bestaande versluren. Mocht u een ander probleem aan uw meubel hebben, verzoeken wij u contact op te nemen met uw meubeldealer.

**PL** Nasz bezpośredni serwis części montażowych  
 Jeżeli brakuje części konstrukcyjnych do montażu, prosimy o przesłanie nam niniejszej karty serwisowej na niżej podany adres e-mailowy. W ten sposób możemy przesyłać Państwu tylko brakujące części. W przypadku innych niż awarie dotyczących mebla, prosimy zgłaszać się do swojego meblowego, w którym został dokonany zakup.

**HR** Servis za običaj  
 U slučaju da nedostaje neki od običaj meblu vas da na dolje navedenu mail adresu pošaljete naš službeni obrazac. Na ovaj način mogu se dostaviti samo običaj. U slučaju da imate dodatne prigovore vezane uz komad namještaja molimo vas da se obratite izravno trgovini namještaja gdje je isti kupljen.

**HU** Direktai gátlakunk vasalok esetén  
 Ha hiányzik egy vasalat, ezt a kártyát közvetlenül elküldheti az alábbi e-mail címre. Azonban csak a vasalatot tudunk így küldeni. Amennyiben másfajta reklamációt áll ten bútorral kapcsolatban, forduljon közvetlenül a bútoráruházhoz.

**SK** Náš priamy servis pre časti kování  
 Ak by Vám chýbala niekajá časť kování, môžete poslať túto službu kartu priamo e-mailom na nižšie uvedenú adresu. Touto cestou však môžeme poslať iba tylné spojky. Ak by ste mali inú reklamáciu ohľadom vášho nábytku, obráťte sa priamo na Vašu predajňu nábytku.

**SLO** Náš direktni uslužba storitev za delce  
 Če vam manjka kakšno delce, lahko to serviso kartico pošljete po e-pošti direktno na spodnji naslov. Po tej poti vam lahko pošljemo samo delce. Če delite nekatere dodatne druge delce pohištva, se obrnite neposredno na vašo trgovino pohištva.

**RO** Servisul nostru direct pentru feronerie  
 În cazul în care vă lipsește o piesă de feronerie puteți să trimiteți direct această card de service prin e-mail la adresa de mail din listă. În cazul în care aveți alte reclamații sau probleme legate de produsul comandat, vă recomandăm să vă adresați direct la magazinul dvs. de mobilier.

**RUS** Наш прямой сервис для поставки фурнитуры  
 Если обнаружено, что Вы не получили того или иного элемента фурнитуры, Вы можете отправить сервисную карту по адресу непосредственно на нижеуказанный адрес электронной почты. Однако, только об этом мы можем переписать только фурнитуру. Если у Вас возникли другие претензии относительно приобретенной мебели, пожалуйста, обращайтесь непосредственно в организацию, осуществляющую продажу.

**S** M'r direktionscard är för beständel  
 Om du saknar en beständel kan du skicka detta servicekort till oss till produktionsen som anges nedan. Tänk på att detta är den enda möjligheten att skicka beständel till dig. Om du vill reklamera din möbel av annan anledning måste du kontakta ditt möbelhus direkt.

**ES** Nuestro servicio directo para accesorios  
 Si le falta algún accesorio, puede enviar esta tarjeta de servicio directamente a la siguiente dirección. No obstante, por este método solo podemos enviar accesorios. Si tiene alguna otra objeción sobre su mueble, consulte directamente con su mueblería.

**TR** Donatılar için doğrudan servisi için  
 Bir donatı eksikliği bu servise ilişkin doğrudan sorgularla bulmanız adına doğrudan mail ile yazabilirsiniz. Sadece bu yolla donatıları gönderilebilir. Mobilyanızla ilgili diğer konular için doğrudan mobilya satıcınıza danışın.

nr	L [mm]	B [mm]	T [mm]	Menge	Coll
1	350	300	16	1	1/1
2	350	300	16	1	1/1
3	968	266	16	1	1/1
4	968	283	16	1	1/1
5	968	332	16	1	1/1
6	962	347	16	1	1/1

