

1 → 2 → 3 ...

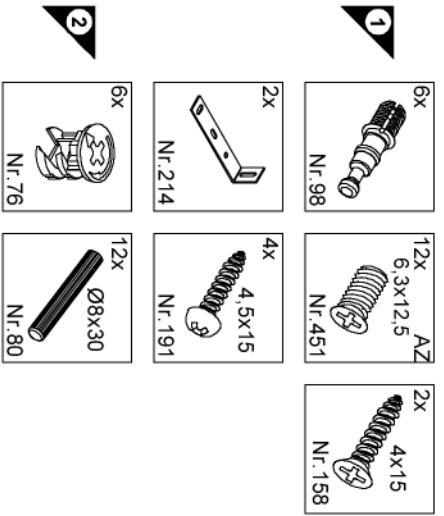

Service-Hotline
01805-678101
0,14€ pro Minute
+ +49 für Österreich
Auslandstarif pro Minute
service@jaka-bkl.de
voor Nederland en België
00800-40119350
benelux@jaka-bkl.de

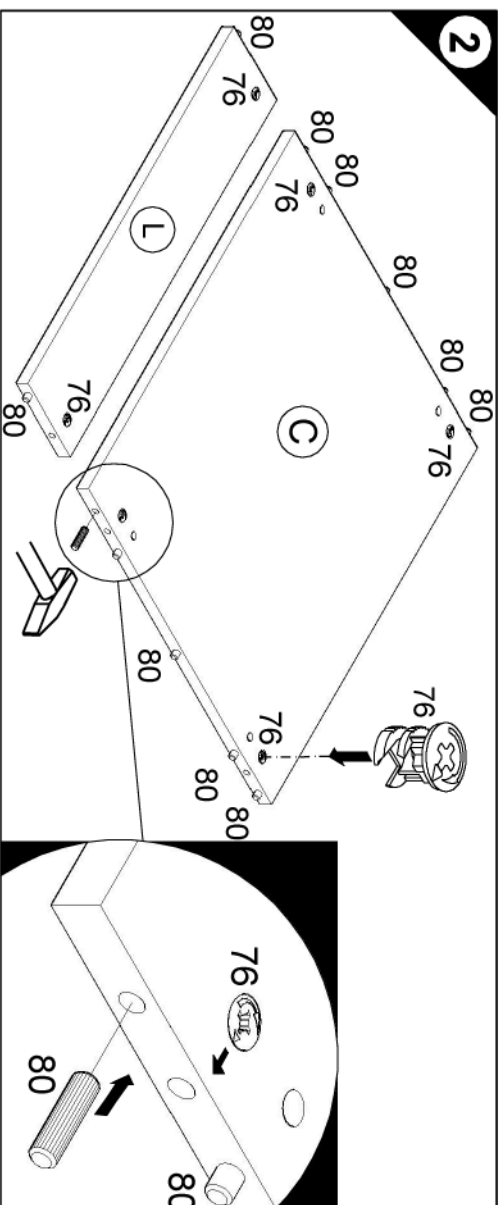
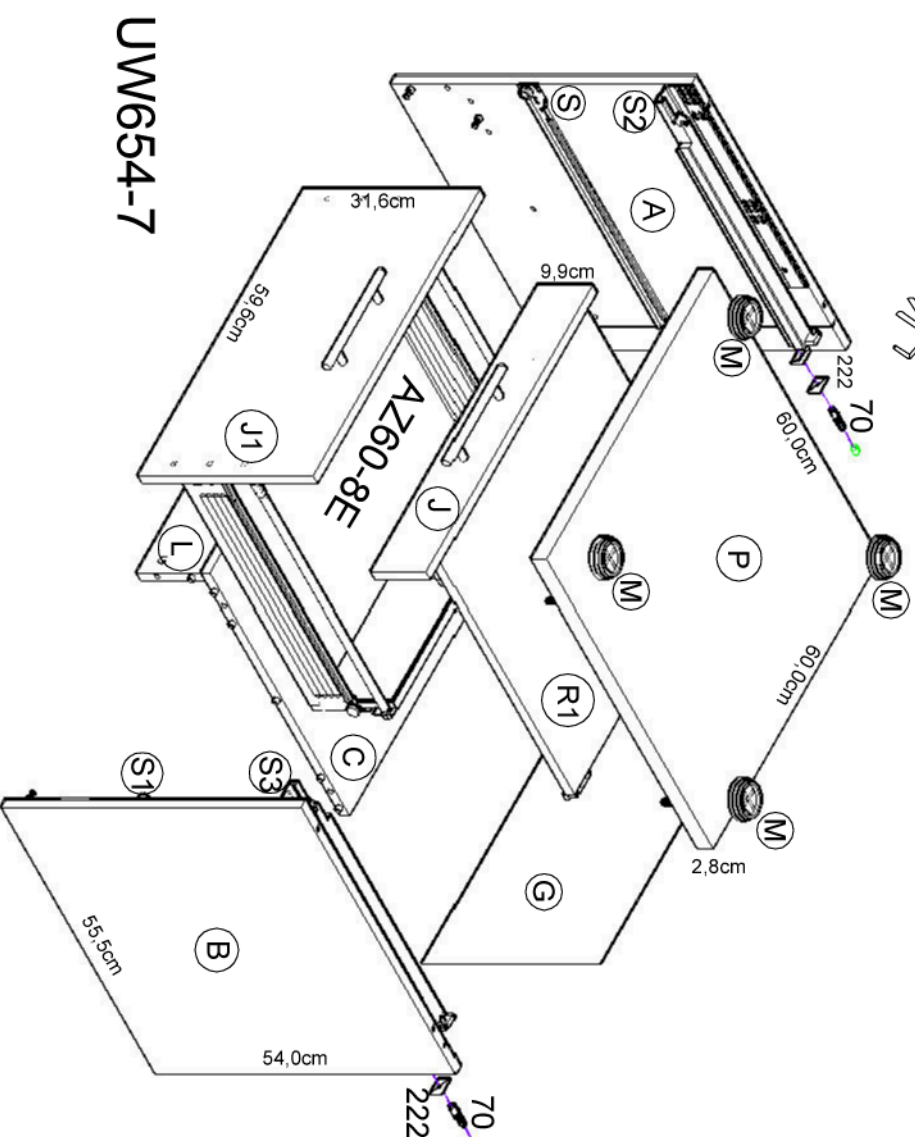
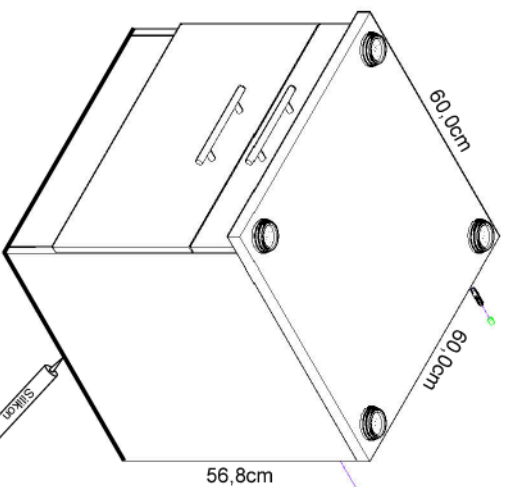

Montageanleitung

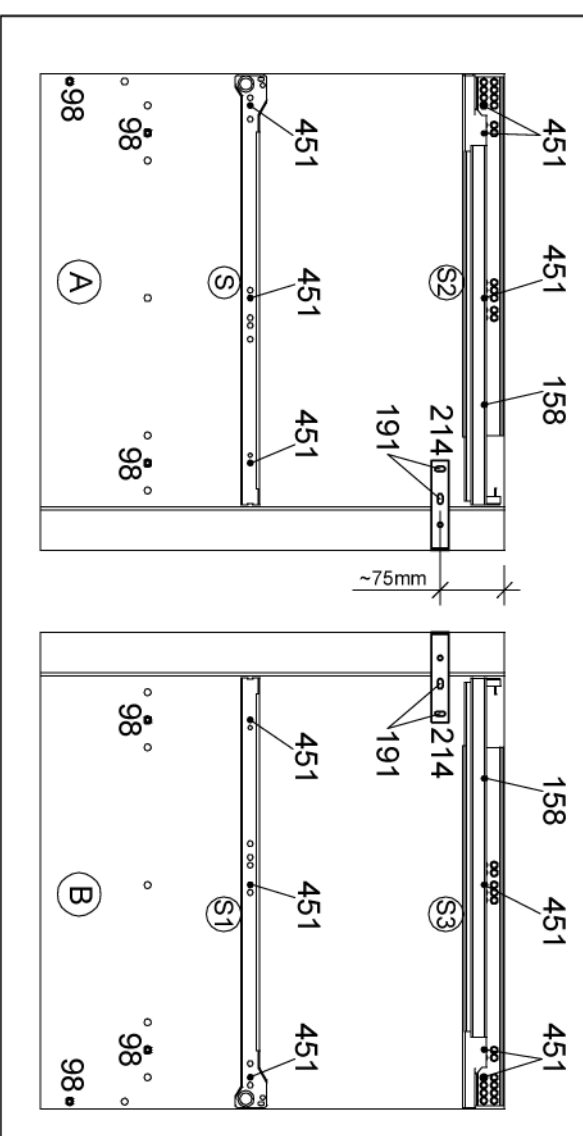
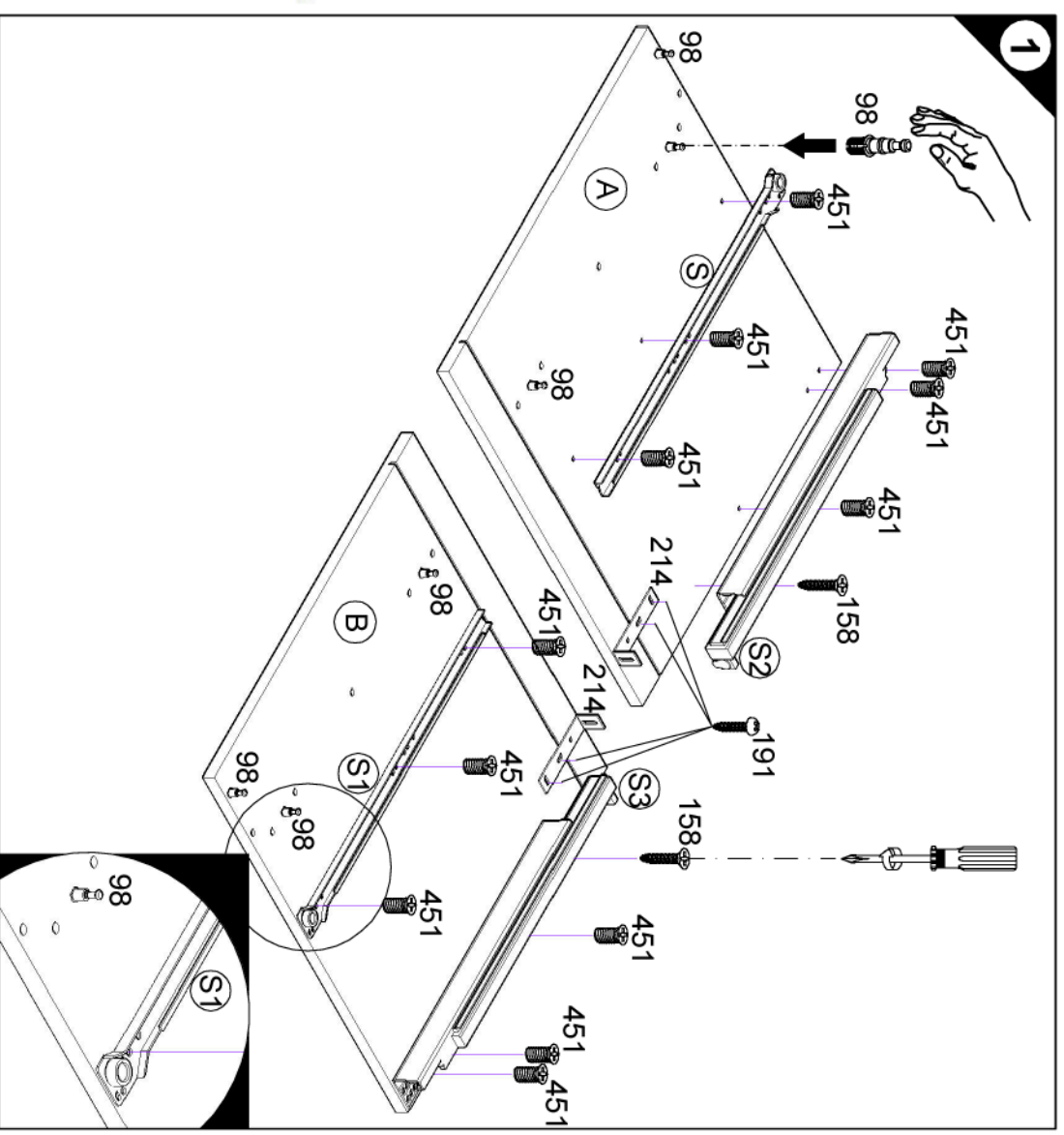

1 → 2 → 3 ...

- 5 4x 8,3x35 Nr.217
- 6 6x 3x20 Nr.197
- 7 2x Nr.515 4x 3,5x25 Nr.200
- 1x L Nr.513 1x R Nr.514
- 4x 3,5x15 Nr.181
- 2x Nr.523 8x 6,3x13 Nr.274
- 2x Ø8 Nr.70 2x Nr.222
- 2x 4,5x45 Nr.175
- 2x 4x30 Nr.424

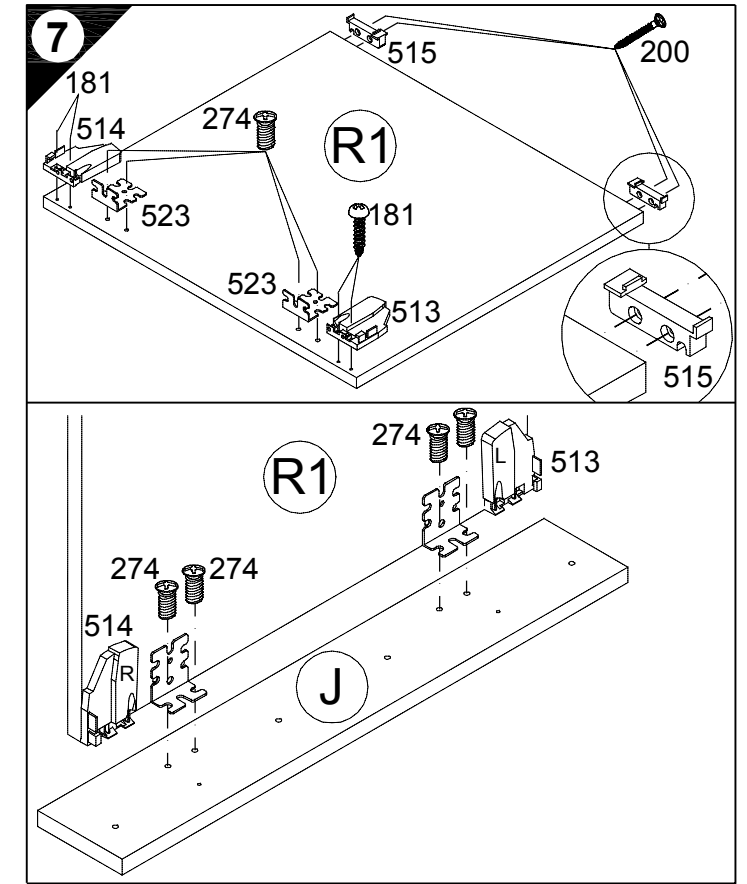
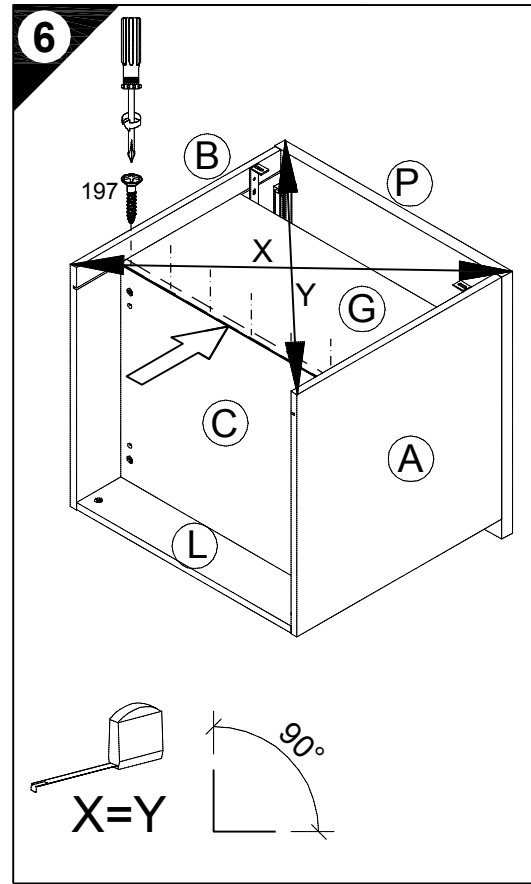
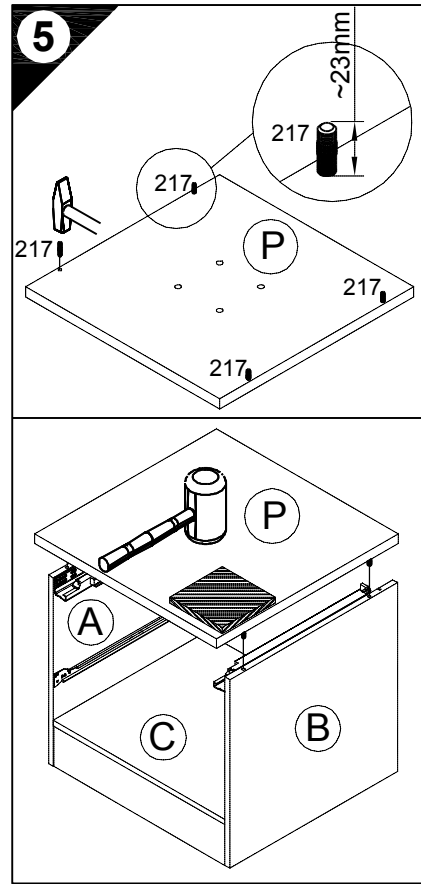
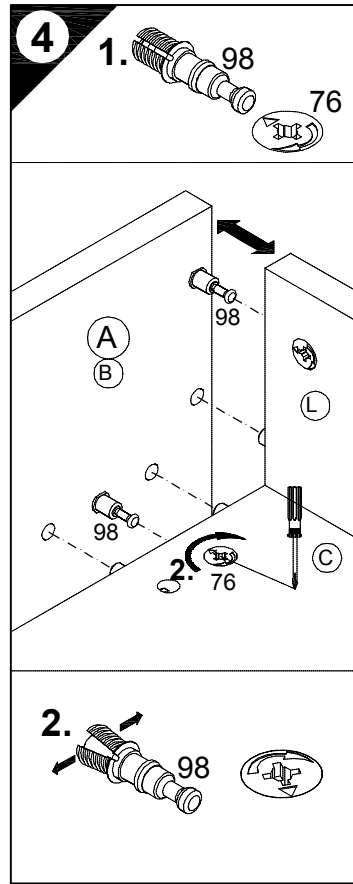
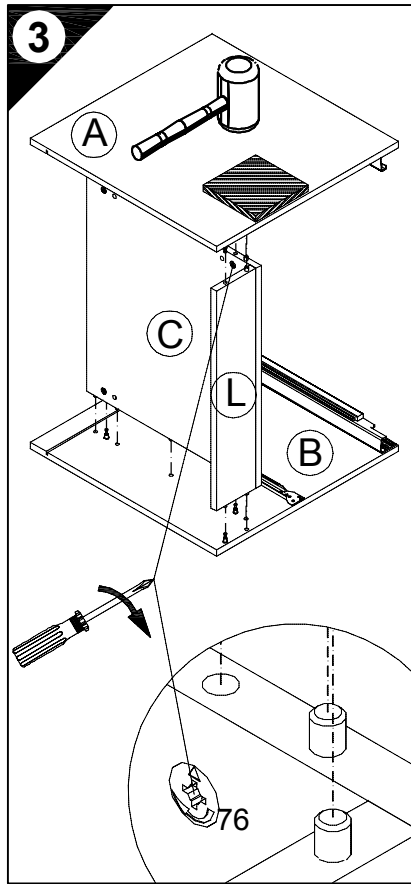

- 8**
- D Holzunterlage verwenden!
Front andrücken, scharfen Bohrer verwenden und mit wenig Druck durchbohren!
 - GB Use a wooden base!
Press front down, use sharp drill bit and, by applying slight pressure, drill a hole
 - F Utiliser un support en bois !
Appuyer sur la façade, utiliser un foret bien affûté et percer en appliquant une faible pression !
 - NL Houten onderlegger gebruiken!
Druk het front aan, gebruik een scherpe boor en oefen bij het boren weinig druk uit!
 - E ¡Utilizar una base de madera!
¡Presionar el frente, utilizar una broca afilada y taladrar con poca presión!
 - I Utilizzare una base di legno!
Appoggiare la facciata, utilizzare una punta di trapano affilata e trapanare esercitando solo una leggera pressione!
 - RUS Использовать деревянную подложку!
Прижать фасад, использовать острое сверло и просверлить с незначительным давлением!
 - PL Używać podkładkę z drewna!
Docisnąć front, użyć ostrego wiertła i przewiercić, używając małej siły nacisku!

- H Alkalmazzon fa alátétet!
Nyomja le az előlapot, használjon éles fúrót, és kis nyomással fúrja át!
- CZ Použijte dřevěný podklad!
Přitlačte čelo, použijte ostrý vrták a provrtejte pomocí malého tlaku!
- SLO Uporabite leseno podlago!
Pritisnite ličnico ter z ostrim svedrom in z majhnim pritiskom izvrtajte luknjo!
- FIN Käytä puualustaa!
Paina etulevy paikoilleen, käytä terävää poranterää ja poraa reikä vain kevyesti painamalla!
- S Använd ett träunderlag!
Tryck fronten mot underlaget, använd vass borr och borra igenom med ett lätt tryck!
- SK Použite drevený podklad!
Přitlačte front, použite ostrý vrták a prevŕtajte miernym tlakom!
- RO suport de lemn! Împingeți frontul, utilizați un burghiu ascuțit și perforați exercitând doar o presiune redusă!
- TR Ahşap taban kullanın!
Önden bastırın, keskin matkap ucu kullanın ve az basınç uygulayarak delin!

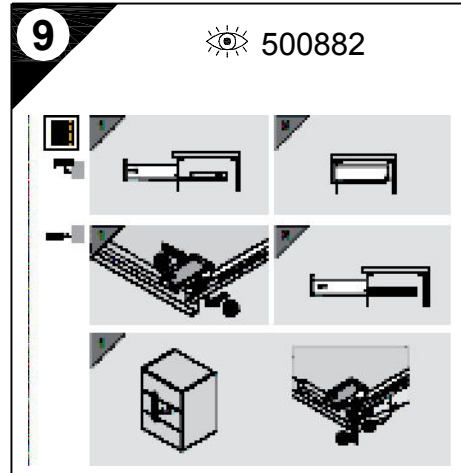
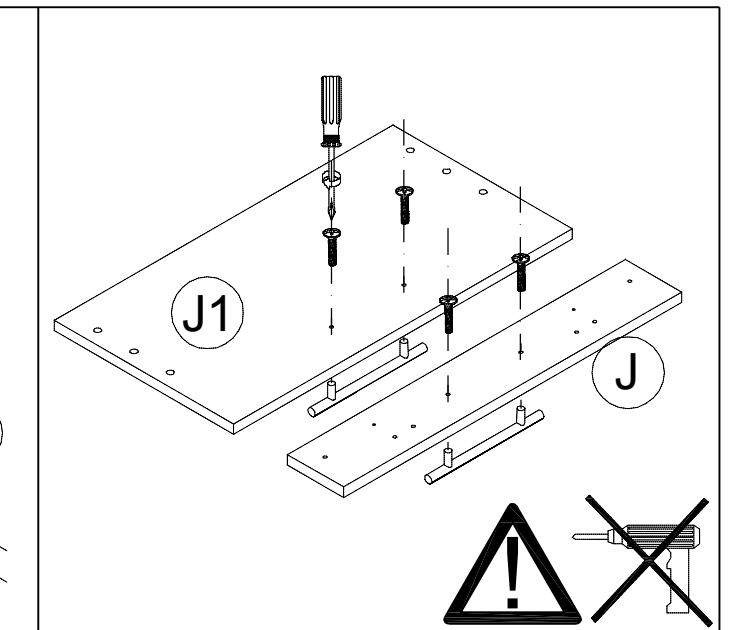
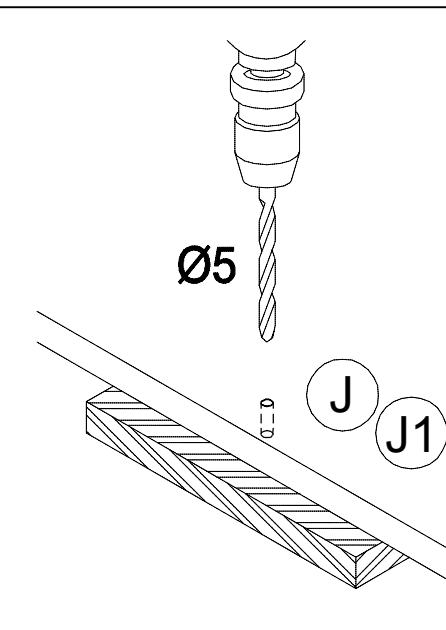

- 10**
- D Wandbefestigung zwingend erforderlich!
 - GB Wall fixing essential!
 - F A fixer impérativement au mur!
 - NL Wandbevestiging dringend vereist!
 - E ¡Fijación en la pared absolutamente necesaria!
 - I Il fissaggio alla parete è indispensabile!
 - RUS Крепление к стене обязательно!
 - PL Mocowanie do ściany bezwzględnie konieczne!
 - H A falra történő rögzítésre feltétlenül szükség van!
 - CZ Nástěnná montáž nezbytně nutná!
 - SLO Obvezna je pritrditev na steno!
 - FIN Kiinnitettävä ehdottomasti seinään!
 - S Ett väggfäste är absolut nödvändigt!
 - SK Nutná montáž na stenu!
 - RO Fixarea la perete este neapărat necesară!
 - TR Duvara sabitlenmesi kesinlikle gerekir!

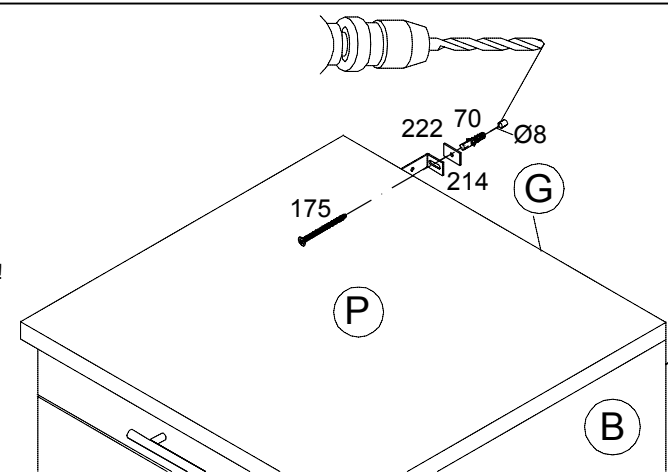

- D Untergrund und Befestigungsmittel auf Eignung prüfen!
- GB Check substructure and fixings for suitability!
- F Contrôler si le support et les moyens de fixation sont bien adéquats !
- NL Ondergrond en bevestigingsmateriaal op functionaliteit controleren!
- E ¡Comprobar el suelo y los medios de fijación en cuanto a su aptitud!
- I Controllare l'idoneità del fondo e del materiale di fissaggio!
- RUS Основание и крепежный материал проверить на пригодность!
- PL Podłoże oraz materiały do zamocowania sprawdzić na ich przydatność!
- H Az alapfelületet és a rögzítő anyagokat megfelelőség szempontjából ellenőrizni kell!
- CZ Přezkoušejte podklad a vhodnost upevňovacích prostředků!
- SLO Preverite, če se ujemajo spodnja stran in pritrdilna sredstva!
- FIN Tarkista alustan ja kiinnitysvälineiden sopivuus!
- S Kontrollera att underlaget och fästmedlen är lämpliga!
- SK Preverte vhodnosť podkladu a upevňovacích prostriedkov!
- RO Verificați caracterul adecvat al suprafeței suport și al mijloacelor de fixare!
- TR Zeminin ve bağlanı elemanlarının uygunluğunu kontrol edin!

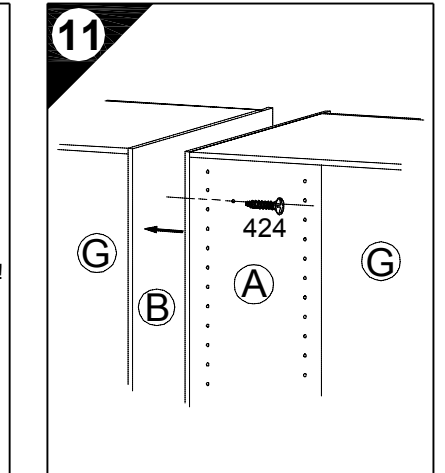

TANDEM

blum



550H
560H
566H

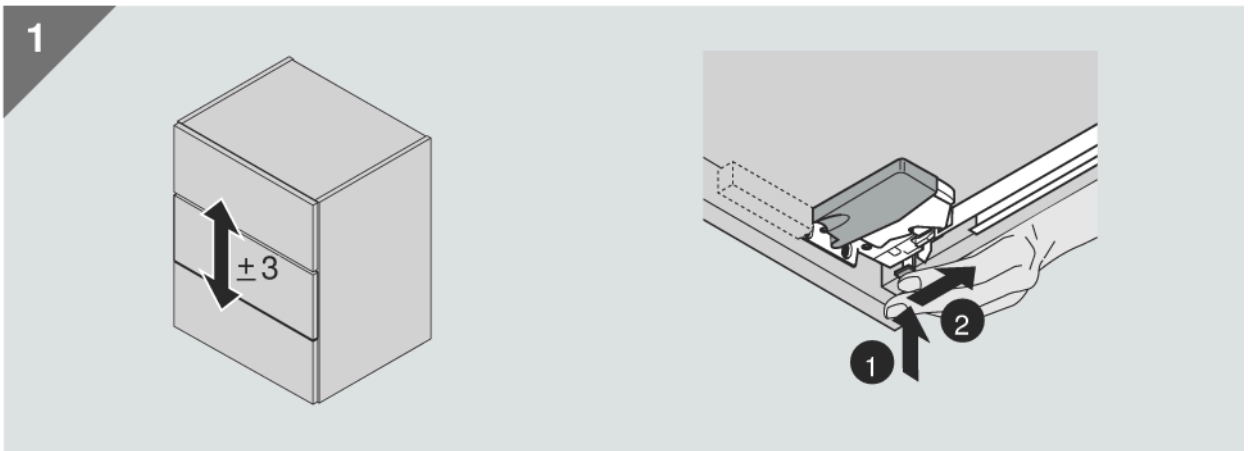
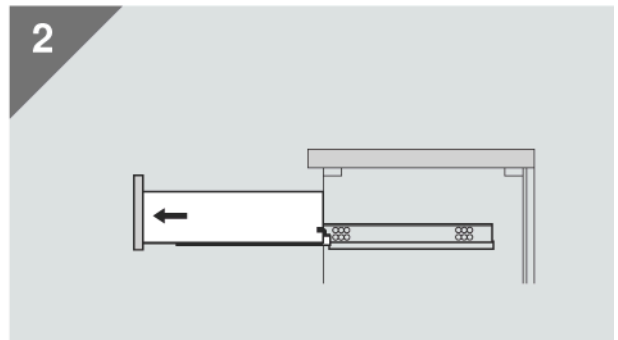
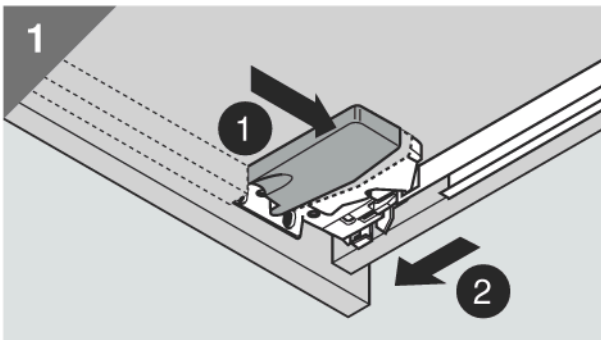
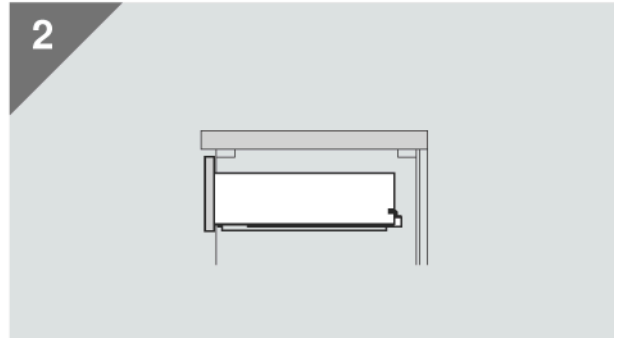
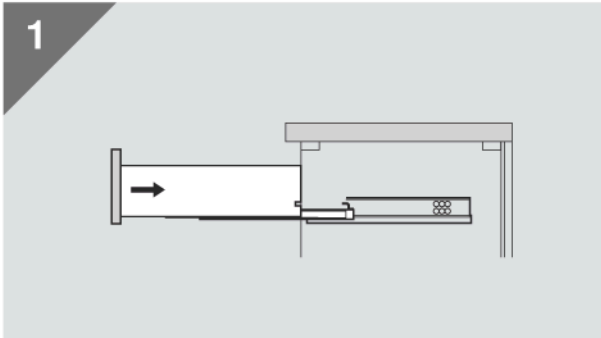

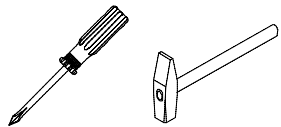

Variante 1 METABOX

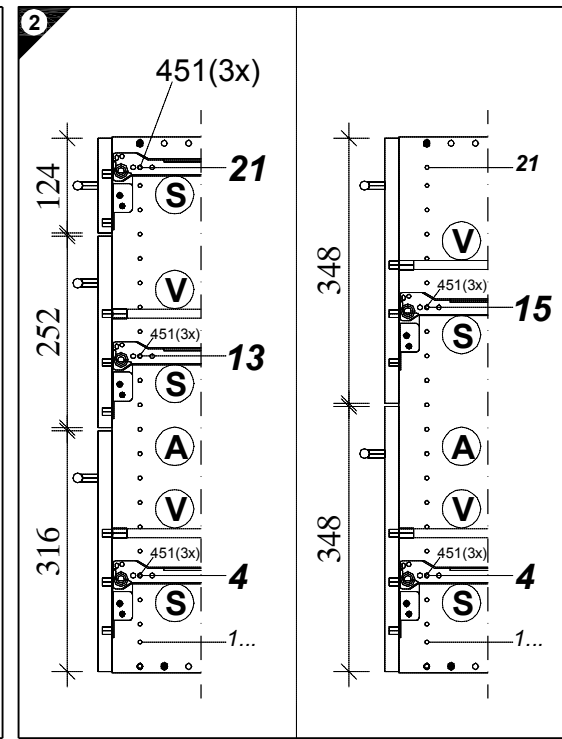
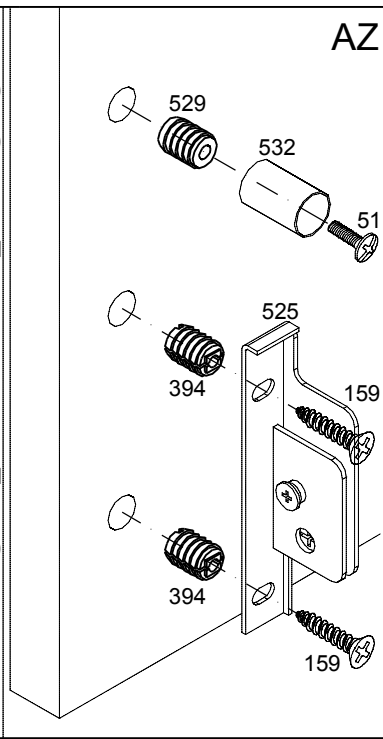
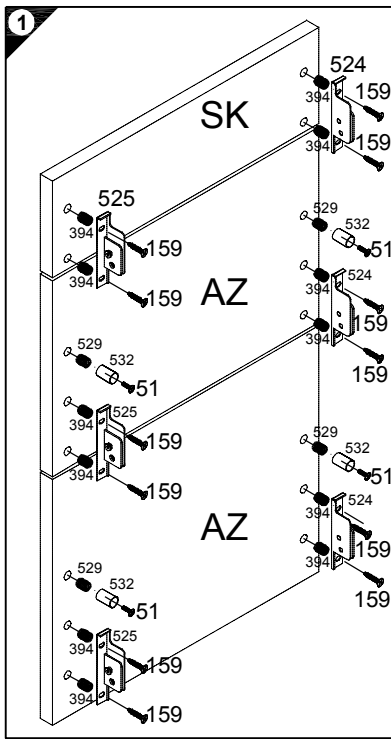
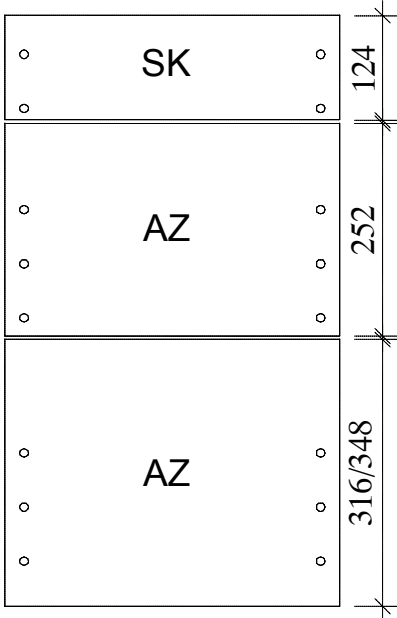

- 1 → 2 → 3 ...
- 4x Nr.394
 - 2x AZ Nr.529 Ø10,6/M4
 - 1x Nr.524
 - 1x Nr.525
 - 4x 4 x 14 Nr.159
 - 2x AZ Nr.532
 - 2x M4 x 9 AZ Nr.51
 - 6x 6,3 x 13 Nr.451

Variante 2 METABOX

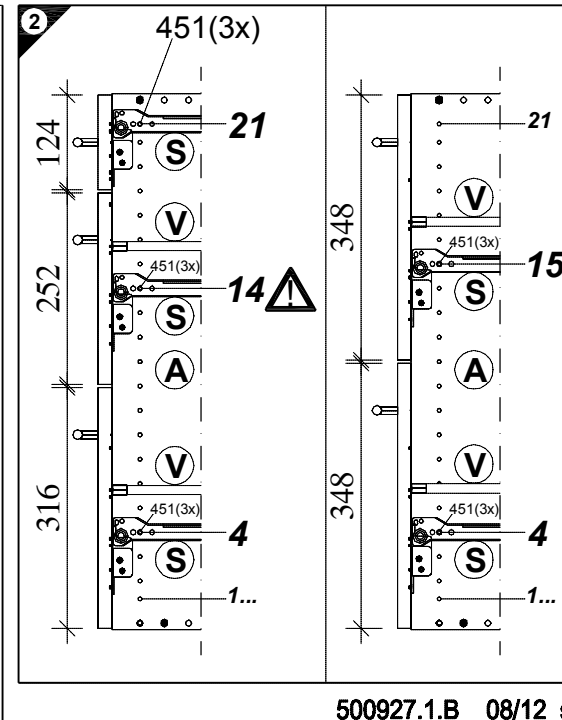
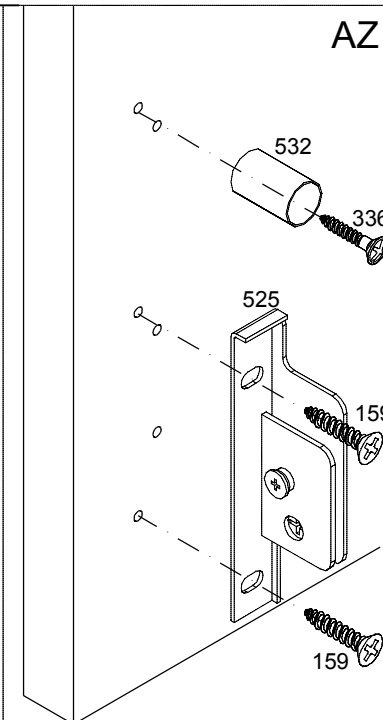
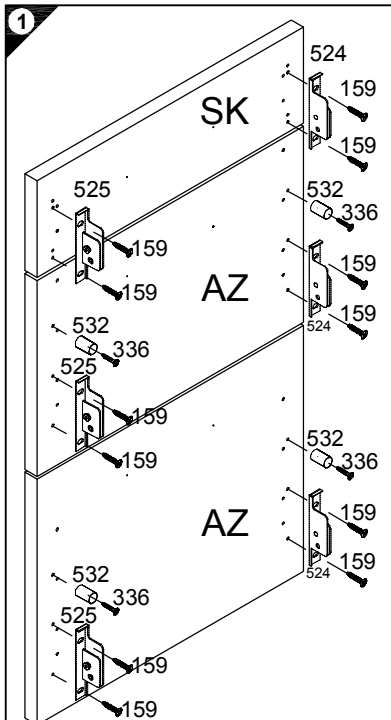
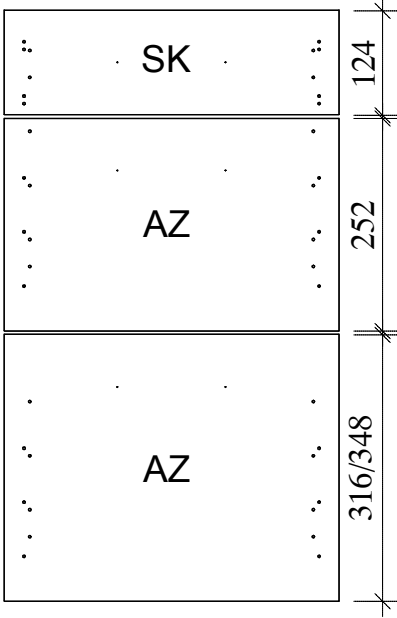

- 1 → 2 → 3 ...
- 1x Nr.524
 - 1x Nr.525
 - 4x 4 x 14 Nr.159
 - 2x AZ Nr.532
 - 2x AZ 4 x 15 Nr.336
 - 6x 6,3 x 13 Nr.451

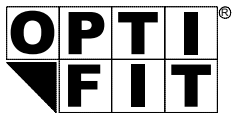

Optifit Jaka-Möbel GmbH
Jaka Straße 3
D-32351 Stemwede-Wehden

Montageanleitung



Optifit Jaka-Möbel GmbH
Jaka Straße 3
D-32351 Stemwede-Wehden

Service-Hotline
01805-678101
0,14€ pro Minute
++49 für Österreich
Auslandstarif pro Minute
service@optifit.de
voor Nederland en België
00800-40119350
benelux@optifit.de

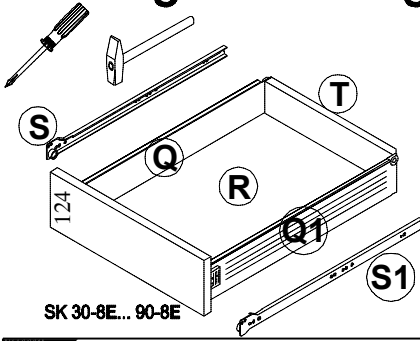

SK 30-8E... 90-8E

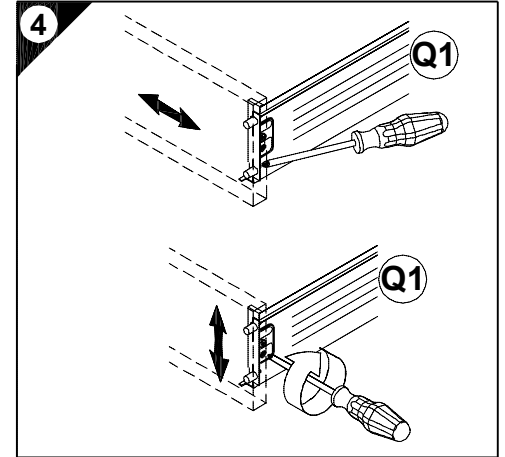
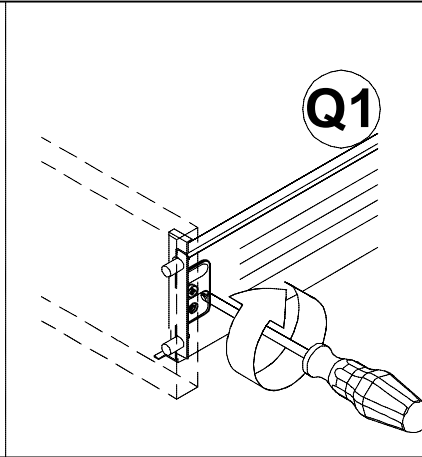
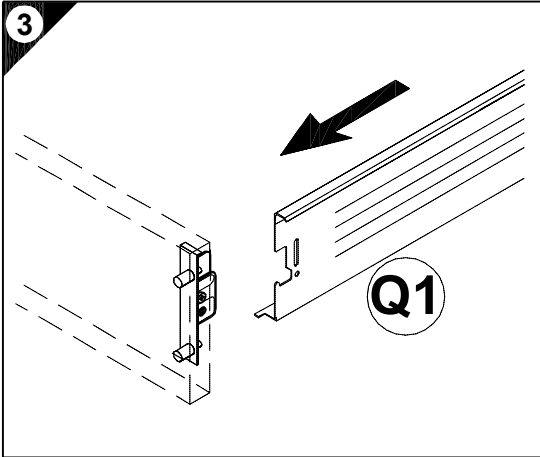
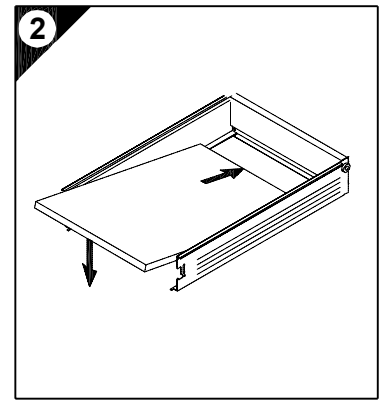
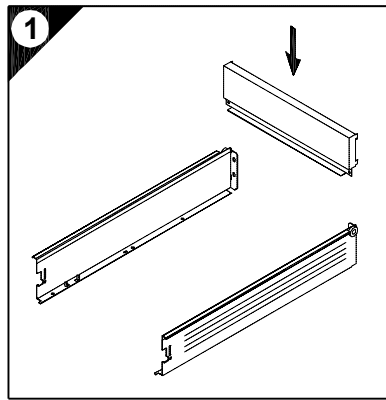

Ersatzteile/Spare parts/pièces de rechange/Reserveonderdelen/Piezas de recambio/Ricambi/Запасные части/Części zamiennel/pótkalkatrészek/Náhradní části/Nadomestni deli/varaosat/reservdelar

30cm SK 30-8E	Q E946001	Q1 E946002	R E941902	S E946003	S1 E946004	T E946019
40cm SK 40-8E	Q E946001	Q1 E946002	R E941907	S E946003	S1 E946004	T E946020
50cm SK 50-8E	Q E946001	Q1 E946002	R E941908	S E946003	S1 E946004	T E946021
60cm SK 60-8E	Q E946001	Q1 E946002	R E941909	S E946003	S1 E946004	T E946017
90cm SK 90-8E	Q E946001	Q1 E946002	R E941913	S E946003	S1 E946004	T E946018

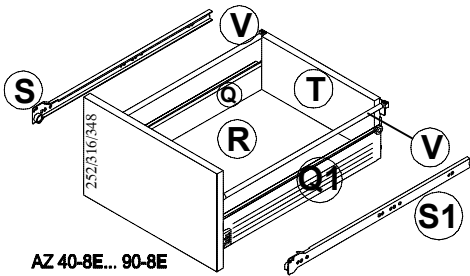

AZ 40-8E... 90-8E

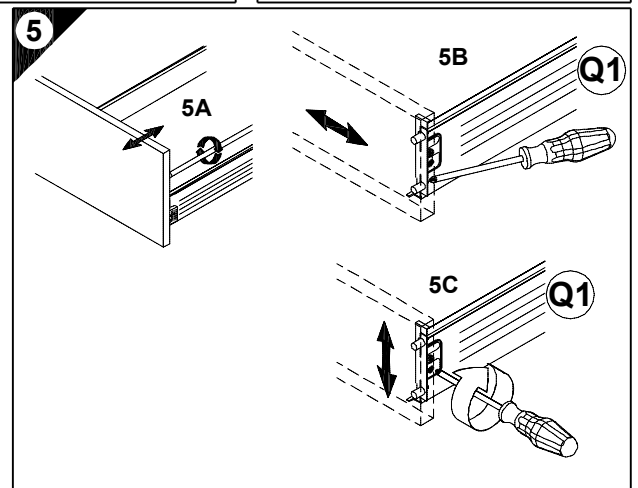
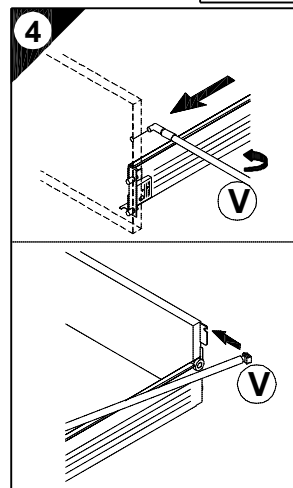
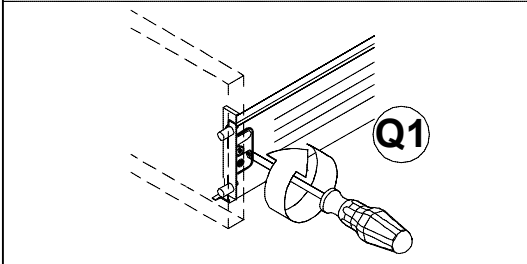
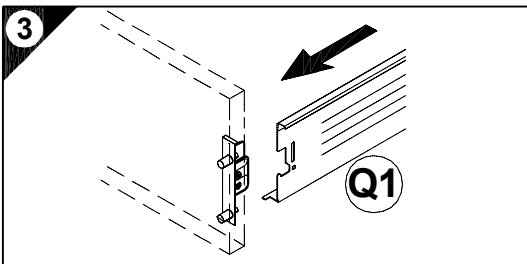
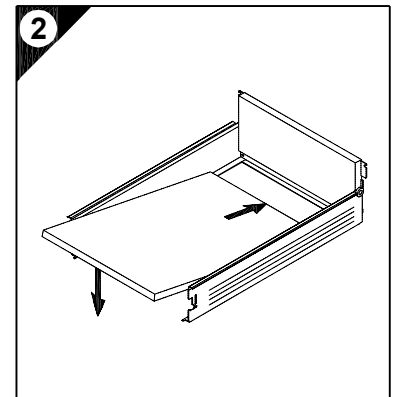
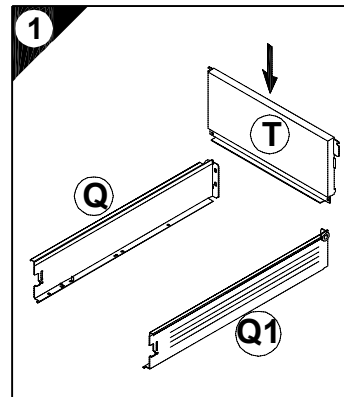

Ersatzteile/Spare parts/pièces de rechange/Reserveonderdelen/Piezas de recambio/Ricambi/Запасные части/Części zamiennel/pótkalkatrészek/Náhradní části/Nadomestni deli/varaosat/reservdelar

40cm AZ 40-8E	Q E946001	Q1 E946002	R E941907	S E946003	S1 E946004	T E946022	V E946006
50cm AZ 50-8E	Q E946001	Q1 E946002	R E941908	S E946003	S1 E946004	T E946023	V E946006
60cm AZ 60-8E	Q E946001	Q1 E946002	R E941909	S E946003	S1 E946004	T E946024	V E946006
80cm AZ 80-8E	Q E946001	Q1 E946002	R E941911	S E946003	S1 E946004	T E946025	V E946006
90cm AZ 90-8E	Q E946001	Q1 E946002	R E941913	S E946003	S1 E946004	T E946013	V E946006